

NEW MEXICO DEPARTMENT OF TRANSPORTATION

RESEARCH BUREAU

Innovation in Transportation

Field and Laboratory Evaluation of Warm Mix Asphalt (WMA) – Phase 1

Prepared by:

University of New Mexico
Department of Civil Engineering
Albuquerque, NM 87131

Prepared for:

New Mexico Department of Transportation
Research Bureau
7500 Pan American Freeway NE
Albuquerque, NM 87109

In Cooperation with:

The US Department of Transportation
Federal Highway Administration

Report NM13MSC-04

AUGUST 2014

SUMMARY PAGE

1. Report No. NM13MSC-04		2. Recipient's Catalog No.	
3. Title and Subtitle Field and Laboratory Evaluation of Warm Mix Asphalt (WMA) – Phase 1		4. Report Date August 30, 2014	
5. Author(s): Rafiqul A. Tarefder and Jielin Pan		6. Performing Organization Report No.	
7. Performing Organization Name and Address University of New Mexico Department of Civil Engineering, MSC01 1070 1 University of New Mexico Albuquerque, NM 87131		8. Performing Organization Code 456-385	
		9. Contract/Grant No. NM13MSC-04	
10. Sponsoring Agency Name and Address Research Bureau, NMDOT 7500B Pan American Freeway PO Box 94690 Albuquerque, NM 87199-4690		11. Type of Report and Period Covered Final Report April 01, 2013 to August 30, 2014	
		12. Sponsoring Agency Code	
13. Supplementary Notes This project is funded by the New Mexico Department of Transportation (NMDOT)			
14. Abstract This report summarizes the current state of Warm Mix Asphalt (WMA) technologies in the U.S. and in New Mexico. It is found that a number of WMA technologies, as many as 35, are currently available under three categories of WMA: foaming, organic additive, and chemical additive. However, it is not clear though whether and what specific WMA technology works better than other. Being a new technology in US, WMA lacks information on long-term field performances. Written survey revealed that New Mexico uses only two WMA technologies: Evotherm and foaming. Field visual inspections of six WMA projects: three evotherm and three foaming concluded that overall WMA pavements are performing well in New Mexico. However six projects evaluated were only 1-3 year old, and in many cases WMA were covered by open graded friction course (OGFC) layer. Therefore field inspection results should be used carefully. All most all the projects surveyed were rehabilitation project (mill and fill) and suffers from traverse and reflective cracking on the shoulder and edge of pavements. Construction data revealed that, most foaming projects use mixing temperature around 300 °F, which is slightly higher than the traditional WMA mixing temperature of 275 °F or below. Analysis of pavement distress data, gathered from pavement management system (PMS) database shows that HMA performs slightly better than foamed WMA, which performs slightly better than evotherm WMA in New Mexico. This study also performs a critical review of the laboratory and field test methods, devices, procedures and pavement performances. It is shown that HMA mix design procedure and performance testing devices are applicable to WMA with a very slight difference. In general, air voids, rutting resistance, dynamic modulus of WMA mixture are slightly lower than control HMA. Fatigue life and low temperature cracking resistance of WMA are comparable to hot mix asphalt (HMA). WMA pavements are more likely to be susceptible to moisture-related damages during their early life as compared to HMA pavements. However, the difference between HMA and WMA moisture damages is less after WMA mixtures have experienced aging. Finally, this study makes recommendations for Phase 2 study to evaluate volumetric properties, rutting, modulus, fatigue cracking, low temperature cracking, and moisture susceptibility, and workability and compactability of evotherm and foaming WMA technologies in New Mexico. Recommendations are also made to evaluate other concerns that were raised during this study. Specifically concerns and issues related to recycled asphalt pavement (RAP) incorporation, oxidative aging of WMA, and performance of WMA OGFC should be addressed in Phase 2 through field and laboratory testing.			
15. Key Words WMA, NMDOT, Mix Design, Testing, Evotherm, Foaming		16. Distribution Statement Available from NMDOT Research Bureau	
17. Security Classification of this Report None	18. Security Classification of this page None	19. Number of Pages 147	20. Price N/A

THIS PAGE LEFT BLANK INTENTIONALLY

Field and Laboratory Evaluation of Warm Mix Asphalt (WMA) – Phase 1

Final Report: NM13MSC-04
April 1, 2013 - August 30, 2014

Prepared by:

Rafiqul A. Tarefder, Ph.D., P.E.
Professor

Jielin Pan
Ph.D. Candidate

Department of Civil Engineering
1 University of New Mexico
MSC01 1070
Albuquerque, N.M. 87131

A Report on Research Sponsored by:

New Mexico Department of Transportation
Research Bureau
in Cooperation with
The U.S. Department of Transportation
Federal Highway Administration

August 2014

Research Bureau
New Mexico Department of Transportation
7500B Pan American Freeway NE
PO Box 94690
Albuquerque, NM 87199-4690
(505)-841-9145
<http://NMDOTResearch.com>

PREFACE

The research reported herein represents the current state of Warm Mix Asphalt (WMA) in USA and in New Mexico, a review of WMA technologies that are currently being used in New Mexico for constructing pavements, visual performances of WMA pavements in New Mexico, and review of methods and devices required for laboratory and field performances of WMA pavements to ensure future success of WMA technology in New Mexico.

NOTICE

The United States government and the State of New Mexico do not endorse products or manufacturers. Trade or manufactures' names appear herein solely because they are considered essential to the object of this report. This information is available in alternative accessible formats. To obtain an alternative format, contact the NMDOT Research Bureau, 7500B Pan American Freeway NE, PO Box 94690, Albuquerque, NM 87199-4690, (505)-841-9145.

DISCLAIMER

This report presents the results of research conducted by the authors and does not necessarily reflect the views of the New Mexico Department of Transportation. This report does not constitute a standard or specification.

ACKNOWLEDGEMENTS

The authors would like to thank the Project Advocates Mr. James Gallegos and Mr. Parveez Anwar, Project Manager Mr. Virgil Valdez, and the Project Technical Panel Mr. Jeff Mann, Ms. Kelly R. Montoya, Mr. Cliff Lucas, Mr. Bryce Simons of NMDOT and Mr. Shawn Hammer of Fisher Sand & Gravel Co. for their support and guidance. Thanks go to Mr. Jerry Hickman at District 2, Mr. Kenneth Murphy at District 3, Mr. David Gonzales at District 4, Mr. Frank Salazar, Mr. Donald R. Abeyta, Mr. Morris H. Williams, and Mr. Johnny Gallegos at District 6 for their participations in written surveys, emails, and for providing information of selected WMA projects.

The authors would like to thank Mr. Mohammad Moabed and Mr. Bob Hicks of HollyFrontier Refining & Marketing LLC., Mr. Mike O’Leary of MeadWestvaco Corporation and Mr. Shawn Hammer of Fisher Sand & Gravel Co. for participating in the field evaluation trips of WMA projects and sharing their expertise.

The authors also extend their thanks to Mr. Melgoza of the New Mexico Division Office of the Federal Highway Administration (FHWA).

This research project was funded by the NMDOT Research Bureau in cooperation with the FHWA.

TABLE OF CONTENTS

INTRODUCTION	1
Scope.....	Error! Bookmark not defined.
Goals and Objectives	2
Report Organization.....	2
CURRENT STATE OF WMA TECHNOLOGY.....	4
BACKGROUND	4
Definition of WMA.....	4
Brief History	4
Category of WMA	5
Differences between WMA and HMA Design.....	11
Laydown and Compaction Differences between WMA and HMA.....	15
Advantages and Disadvantages of WMA.....	15
State DOT, NCHRP, SHRP, UTC, and FHWA Review	17
Evaluation of Additives	17
WMA Mix Design Method.....	19
WMA Pavement Performance	20
Laboratory Test Procedures	21
WMA TECHNOLOGIES IMPLEMENTED IN NEW MEXICO	23
WATER INJECTION FOAMING PROCESSES USED IN NEW MEXICO.....	23
Double Barrel Green	23
AQUABlack WMA	24
Warm Mix Asphalt System.....	25
CHEMICAL TECHNOLOGY USED IN NEW MEXICO – EVOTHERM.....	26
Evotherm ET	27
Evotherm DAT.....	27
Evotherm 3G.....	28
PRELIMINARY SURVEY OF NMDOT’S WMA PROJECTS.....	30
GENERAL NMDOT’S WMA PROJECTS	30
PROJECT SELECTION.....	31
PRELIMINARY SURVEY	32

Responses from Project Managers	32
Responses from Paving Contractors	33
EVALUATION OF WMA THROUGH FIELD SURVEY	38
EVOTHERM-25% RAP WMA PROJECT ON I-25	38
General Pavement Condition after around 2 Years and 4 Months for the Project	38
Problems/Distresses Found on the Project.....	39
25% RAP HMA CONTROL PROJECT ON I-25	40
General Pavement Condition after around 2 Years and 4 Months for the Project	40
Problems/Distresses Found on the Project.....	41
I-25 WMA VS. I-25 HMA.....	43
EVOTHERM-0% RAP WMA PROJECT ON NM 264	43
General Pavement Condition after 2 Years and 7 Months	43
Problems/Distresses Found on the Project.....	43
Summary	46
EVOTHERM-0% RAP WMA PROJECT ON NM 118	46
General Pavement Condition after 1 Year and 7 Months	46
Problems/Distresses Found on the Project.....	47
Summary	50
EVOTHERM-0% RAP WMA PROJECT ON US 60.....	50
General Pavement Condition after about 5 Months.....	52
Problems/Distresses Found on the Project.....	52
Summary	54
FOAMED-25% RAP WMA PROJECT ON NM 48.....	54
General Pavement Condition after about 6 Months.....	54
Problems/Distresses Found on the Project.....	55
Summary	56
FOAMED-0% RAP WMA PROJECT ON I-40.....	57
General Pavement Condition after around 8 Months	58
Problems/Distresses Found on the Project.....	58
Summary	61
FOAMED-0% RAP WMA PROJECT ON US 60	61

General Pavement Condition after around 17 Months	61
Problems/Distresses Found on the Project.....	62
Summary	65
CONCLUSIONS AND DISCUSSIONS	65
Common Issues	67
WMA vs. HMA	67
Evotherm vs. Foaming	67
Field Survey Limitations.....	69
Best WMA Technologies for New Mexico	69
EVALUATION OF WMA USING PAVEMENT MANAGEMENT DATA	72
METHODOLOGY	72
Pavement Roughness	72
Pavement Distresses.....	72
Pavement Serviceability Index (PSI).....	74
WMA CONDITION DATA ANALYSIS	76
Pavement Roughness (IRI)	76
Raveling and Weathering.....	77
Bleeding	77
Transverse Cracking	78
Fatigue Cracking.....	79
Edge Cracking.....	79
Longitudinal Cracking	80
Patching.....	81
Rutting.....	81
PSI VALUES	82
REMARKS FROM PAVEMENT MANAGEMENT DATA ANALYSIS	85
REVIEW OF WMA PERFORMANCES.....	87
MIX DESIGN TESTS	87
Laboratory Mixer	87
Mix Volumetrics.....	87
Laboratory Testing Protocols.....	89

RUT TESTING.....	89
Asphalt Pavement Analyzer (APA) Test	89
Hamburg Wheel Tracking Device (HWTD) Test.....	91
Flow Number (FN) Test.....	92
Major Differences among APA, HWTD, and FN Tests.....	93
DYNAMIC MODULUS TESTING	93
FATIGUE CRACKING TESTING.....	94
Dynamic Mechanical Analyzer (DMA).....	94
Beam Fatigue Test (BFT)	94
Overlay Test.....	95
LOW TEMPERATURE CRACKING TESTING.....	96
IDT Test	96
MOISTURE SUSCEPTIBILITY.....	97
Evaluation of the Moisture Susceptibility of WMA by NCHRP Project 9-49.....	98
WORKABILITY AND COMPACTABILITY OF WMA.....	98
WMA WITH RAP INCORPORATION	100
OXIDATIVE AGING OF WMA	101
PERFORMANCE OF WMA OGFC.....	102
CONCLUSIONS AND RECOMMENDATIONS	106
CONCLUSIONS.....	106
RECOMMENDATIONS	108
REFERENCES	110
APPENDIX A.....	120
SURVEY OF SEVEN WMA PROJECTS IN NM	120
APPENDIX B.....	125
Survey Responses	125
APPENDIX C.....	136
Guidelines for Project Selection and Materials Sampling, Conditioning, and Testing in WMA Research Studies	136

LIST OF FIGURES

FIGURE 1 Classification of Mix Asphalt Productions by Temperature Range.....	4
FIGURE 2 WMA System Nozzle of Double Barrel Green.....	23
FIGURE 3 Astec Double Barrel Green System.....	24
FIGURE 4 AQUABlack WMA System.....	25
FIGURE 5 Terex WMA System.....	26
FIGURE 6 Chemical Process of Evotherm Package.....	27
FIGURE 7 Selected Seven WMA projects in New Mexico.....	32
FIGURE 8 Pavement in Good Condition from the Beginning to the Ending Mileposts.....	39
FIGURE 9 Binder Balls on the Pavement.....	39
FIGURE 10 Transverse Cracking on the Edge of OGFC and Shoulders.....	40
FIGURE 11 General Pavement Condition of the HMA Control Project.....	41
FIGURE 12 Binder Balls.....	41
FIGURE 13 Transverse Cracking on Shoulders.....	42
FIGURE 14 Joint Cracking and Pitting.....	42
FIGURE 15 General Pavement Condition of the WMA Project.....	43
FIGURE 16 Raveling and Weathering.....	44
FIGURE 17 Reflective Cracking and Joint Cracking.....	45
FIGURE 18 Longitudinal Cracking.....	45
FIGURE 19 Binder Balls.....	45
FIGURE 20 General Pavement Condition of the WMA Project.....	47
FIGURE 21 Binder Balls.....	48
FIGURE 22 Segregation.....	48
FIGURE 23 Transverse Cracking.....	49
FIGURE 24 Longitudinal Cracking.....	49
FIGURE 25 Moisture Stripping.....	50
FIGURE 26 Road Constructions.....	51
FIGURE 27 Laydown Temperatures.....	51
FIGURE 28 Road after Construction.....	52
FIGURE 29 Pavement in Good Condition from the Beginning to the Ending Mileposts.....	52
FIGURE 30 White Marks and Cinders (Left) and Binder Balls (Right).....	53
FIGURE 31 Transverse Cracking on Shoulders.....	53
FIGURE 32 Longitudinal Cracking on Shoulders.....	54
FIGURE 33 Pavement in Good Condition from the Beginning to the Ending Mileposts.....	55
FIGURE 34 Binder Balls (Left) and Segregation (Right).....	56
FIGURE 35 Pitting (Left) and Fines Picked Up (Right).....	56
FIGURE 36 Road Condition before WMA Project.....	57
FIGURE 37 Road Condition after Construction.....	58
FIGURE 38 Pavement in very Good Condition from the Beginning to the Ending Mileposts....	58
FIGURE 39 Transverse Cracking on the Existing HMA shoulders.....	59

FIGURE 40 One Binder Ball Found on the WMA Shoulder.	60
FIGURE 41 Works Done on the Shoulder around the End of Project.	60
FIGURE 42 Pavement in Good Condition from the Beginning to the Ending Mileposts.....	62
FIGURE 43 Binder Balls and Pitting.....	63
FIGURE 44 Longitudinal Cracking on the Edge of OCFC and the Existing HMA Shoulder.	64
FIGURE 45 Transverse Cracking on the OCFC Surface and the Existing HMA Shoulder.....	64
FIGURE 46 Expansive Clay Found on the Outside Westbound Shoulder.....	65
FIGURE 47 Comparisons of Mixing and Laydown Temperatures between Evotherm Projects and Foaming Projects.....	68
FIGURE 48 TSR Comparisons between Evotherm Projects and Foaming Projects.....	69
FIGURE 49 Box Plot of IRI for Each WMA Project.	77
FIGURE 50 Box Plot of Distress Rate of Transverse Cracking for Each WMA Project.....	78
FIGURE 51 Box Plot of Distress Rate of Fatigue Cracking for Each WMA Project.	79
FIGURE 52 Box Plot of Distress Rate of Longitudinal Cracking for Each WMA Project.....	80
FIGURE 53 Box Plot of Rut Depth for Each WMA Project.	81
FIGURE 54 Average PSI Value per Mile for Each WMA Project.	85
FIGURE 55 Asphalt Pavement Analyzer (APA).....	90
FIGURE 56 Hamburg Wheel Tracking Device (HWTD).	91
FIGURE 57 Photographs of MTS at UNM.	92
FIGURE 58 Beam Flexural Fatigue Apparatus by GCTS Testing Systems.	95
FIGURE 59 Schematic of Overlay Test.	96
FIGURE 60 SCB Experiment Setup.....	97
FIGURE 61 Illustration of Compaction Energy Index.	103

LIST OF TABLES

TABLE 1 Summary of WMA Products Description.....	5
TABLE 2 Summary of Necessary Modifications for WMA Technologies.	9
TABLE 3 Steps in Design of Dense-Graded HMA and WMA.....	11
TABLE 4 Comparison of Trial Specimen Fabrication Procedures for WMA and HMA Design.	13
TABLE 5 Summary of WMA Projects in New Mexico.....	30
TABLE 6 Basic Information of the Seven Selected WMA Projects.....	31
TABLE 7 Summary of Field Survey.	66
TABLE 7 NMDOT's Distress Evaluation Chart for Flexible Pavements.....	73
TABLE 8 Rutting Evaluation Criteria.	74
TABLE 9 Factors for Extent Ratings and Weight Factors for Flexible Pavement Distresses.	75
TABLE 10 NMDOT's Ranking of Pavement Condition Based on PSI Values.....	76
TABLE 11 Evaluation Dates and Service Lengths of Six WMA Projects.....	76

INTRODUCTION

SCOPE

Warm mix asphalt (WMA) refers to asphalt concrete mixtures that are produced at lower temperatures than the temperatures typically used in the production of hot mix asphalt (HMA). WMA is produced at temperatures 50 to 100 °F (28 to 56 °C) lower than typical HMA, which are typically produced in either batch or drum plants at a discharge temperature of between 280 °F (138 °C) and 320 °F (160 °C). For HMA, it is necessary to use these elevated temperatures to dry the aggregate, coat it with the asphalt binder, and achieve the desired workability. The key to the production of HMA is providing sufficient temperature to reduce the viscosity (i.e. resistance to flow) of the asphalt to adequately coat the aggregate. However, WMA achieves adequate coating by reducing the asphalt viscosity in a number of processes and additives. WMA uses the principles of a wide range of technologies such as: organic, chemical, and foaming processes that allow for production and placement of asphalt mix at lower temperatures than those required by traditional HMA technology. Lower placement temperatures are directly related to improved compaction and in-place densities which are often speculated to increase the life of WMA asphalt pavements or make WMA performances comparable to HMA performances.

WMA technology was first developed in Europe in late 1990s. The United States become interested in WMA around 2004 after realizing WMA's success in Europe. Few state DOTs started using WMA around the timeframe of 2008-10. BY 2012 this technology became popular in entire US. Indeed, New Mexico Department of Transportation (NMDOT) stated using WMA in 2011 (only 2 projects) and continually adopted its increased use. In 2013, NMDOT approved 133 mix designs, of which 35 mix designs (about 26%) used WMA technologies. At any rate, WMA technology is new in USA and in New Mexico. There have been a lot of speculations about its long-term field performances and/or failures because long-term field performance of this technology has not been tested yet.

Furthermore, there are over 35 commercially available WMA technologies in the United States. It is not known yet which technology works better, especially considering New Mexico's local materials, traffic, and weather conditions. For example, some WMA technologies use water as a workability aid; therefore WMA mixtures could be susceptible to moisture damage. With every WMA mixtures, there is the possibility of inadequately dried aggregates at the lower production temperatures, which may affect the binder to aggregate adhesion, moisture susceptibility, and performance. The extent to which each of the different types of WMA technologies impact performances needs to be established in order to provide unbiased performance data and WMA usage guidance to New Mexico's contractors, and asphalt pavement producers.

Therefore, for WMA to be successfully and confidently implemented by the state of New Mexico, a thorough and comprehensive study is needed to ensure whether the performances of WMA is comparable to, or better than the performances of HMA in New Mexico. Also, which WMA technology affects pavement performances in what way needs to be known. To that end, this study (Phase 1) makes an initial attempt to evaluate the best WMA technologies among the ones are now being used in NM through available literature, gathering information and field visual inspection. The final attempts should include long-term performance testing of WMA mix

in the laboratory and in the field, which could not be pursued in Phase 1 study due to time and resource limitations, but can be pursued in a future study (Phase 2).

GOALS AND OBJECTIVES

The primary objectives are to summarize existing practices of WMA technologies in New Mexico and to evaluate the best practice from local and national perspective.

The specific objectives of this study are to:

1. Assess current design, construction, testing, and performance of WMA technologies, with particular emphasis on their suitability for conditions typical of New Mexico pavements, materials, and environments to recommend best WMA technologies for New Mexico.
2. Survey completed and ongoing WMA projects in the State of New Mexico to document difficulties and problems those have presented obstacles during and post construction, and suggest changes in NMDOT practices and specifications.
3. Review best practices for laboratory and field performance testing of WMA technologies to be used in New Mexico.
4. Provide recommendations and estimated cost for subsequent research (Phase 2), if necessary, to meet overall project objective.
5. Document the literature and survey information generated in this research and provide recommendations for the best technologies and test methods for WMA technologies to be used in New Mexico.

REPORT ORGANIZATION

This report consists of eight sections. Section 1 is an introduction to WMA research. Section 2 contains a review of current state of WMA technology, including state DOT, NCHRP, SHRP, UTC, and FHWA review of WMA implementation. Section 3 describes the specific WMA technologies that are currently being used in New Mexico. Section 4 includes written preliminary survey of NMDOT's WMA projects. Section 5 contains evaluation of WMA in New Mexico through field survey or field visual inspections. Section 6 is a synthesis of selected WMA pavement performances based on the pavement management data. Section 7 contains review of laboratory and field performance of WMA. Section 8 provides conclusions based on this study and recommendations for subsequent (Phase 2) research.

THIS PAGE LEFT BLANK INTENTIONALLY

CURRENT STATE OF WMA TECHNOLOGY

BACKGROUND

Definition of WMA

Warm Mix Asphalt (WMA) is an asphalt mixture that is fabricated using principles of a wide range of technologies, such as organic, chemical, and foaming processes that allow for production and placement at lower temperatures than Hot Mix Asphalt (HMA). Such reductions have the obvious multiple benefits. Environmental benefits include cutting fuel consumption and decreasing the production of greenhouse gases. Engineering and construction benefits include better compaction of pavements, the ability to pave at lower temperatures, extending the paving season, and the potential to be able to recycle at higher rates (1).

Figure 1 illustrates the common asphalt classification by the production temperature from cold mix to hot mix (2). It can be seen that for WMA, the range of production temperature is from 212 – 284 °F (100 – 140 °C), which is lower than HMA and higher than Half Warm Mix Asphalt (HWMA). The common mechanism behind WMA is to achieve reduced production and mixing temperatures by reducing mixture viscosity. With HMA, heat is used to dry aggregate and to reduce asphalt viscosity so that the asphalt binder adequately coats the aggregate during mixing. With WMA, the heat is reduced and the asphalt viscosity reduction is assisted by so called WMA technologies (3).

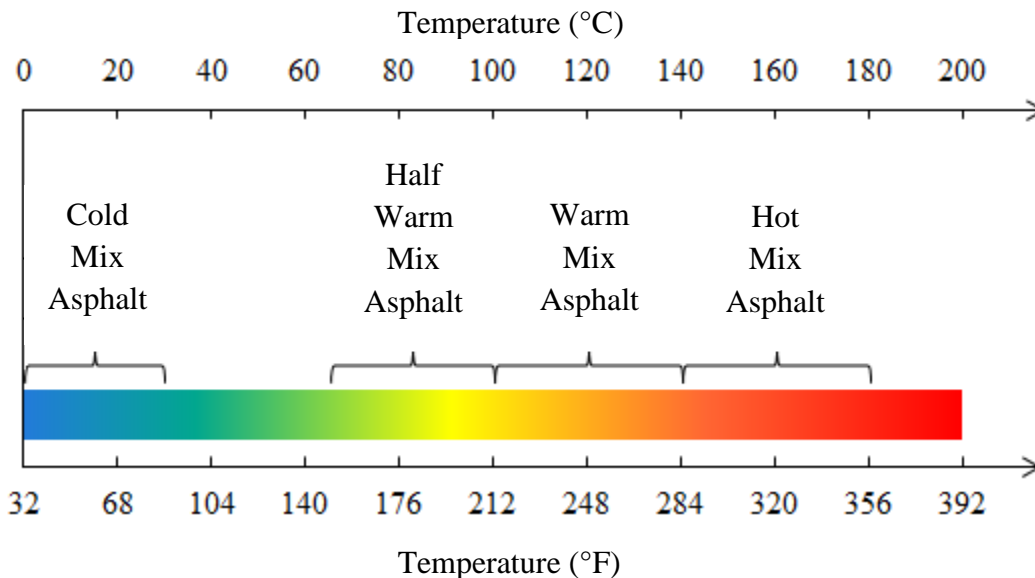

FIGURE 1 Classification of Mix Asphalt Productions by Temperature Range (2).

Brief History

WMA technologies were first introduced in Europe with the German Bitumen Forum in 1997 as an implementation to reduce greenhouse gas emissions. Since then, new WM technologies were constantly emerging. The United States stated first WMA demonstration in 2004. To date, a number of WMA processes have been developed in Europe and the United States (4-5).

Category of WMA

There are three categories of warm mix technologies: (i) addition of organic additives (i.e. Fischer-Tropsch synthesis wax, fatty acid amides, and Montan wax); (ii) foaming processes (subdivided into water-containing and water-based processes); and (iii) addition of chemical additives (usually emulsification agents or polymers) (6). Table 1 shows the products generally used in the three categories of warm mix technologies (7).

TABLE 1 Summary of WMA Products Description (6-7).

Category	Product	Company	Description	Dosage of Additive	Country where product is used	Production Temperature [or Reduction Ranges]
Foaming Processes	AQUABlack WMA	MAXAM equipment	Water based	Not necessary, only water	U.S.A.	Not specified
	Double Barrel Green	Astec	Water based	By choice, anti-stripping agent	U.S.A.	116-135 °C* 120 °C
	Warm Mix Asphalt System	Terex	Water based	Not necessary, only water	U.S.A.	[<32 °C]*
	Ultrafoam GX	Gencor Industries	Water based	Not necessary, only water	U.S.A.	Not specified
	Low Energy Asphalt	LEACO	Water based Hot coarse aggregate mixed with wet sand	Yes, ±0.5% of asphalt binder weight of coating and adhesion additive	U.S.A.; France, Spain, Italy	≤100 °C* 105-124 °C
	Low Emission Asphalt	McConnaughay Technologies	Combination of chemical and water based	Yes, 0.4% of asphalt binder weight	U.S.A.	90 °C* >100 °C
	LT Asphalt Foam	Nynas	Water-based Asphalt binder with hydrophilic additive	0.5-1 % by mass of asphalt binder	Netherlands and Italy	90 °C
	WAM-Foam	Shell and KoloVeidekke	Water based using two binder grades	Anti-stripping agents could be added to soften binder	U.S.A., Norway, worldwide	110-120 °C* 100-120 °C 62 °C
	Advera	PQ Corporation	Water containing Zeolite	0.25% by mixture weight	U.S.A.	[10-20 °C]* [20-30 °C]
	Aspha-Min	Eurovia	Water containing Zeolite	0.3% by mixture weight	U.S.A., France, Germany, worldwide	[30 °C]* [20-30 °C]

TABLE 1 (continued).

Category	Product	Company	Description	Dosage of Additive	Country where product is used	Production temperature [or reduction ranges]
Organic Additives	Sasobit	Sasol	Fischer-Tropsch wax	2.5-3.0% of asphalt binder weight in Germany 1-1.5% of asphalt binder weight in US	U.S.A., E.U., worldwide	[10-30 °C] [*] [20-30 °C] [18-54 °C] 130-150 °C
	Asphaltan A Romonta N	Romonta GmbH	Montan wax for mastic asphalt	1.5-2.0% of asphalt binder weight	Germany	[20 °C]
	Asphaltan B	Romonta GmbH	Refined Montan wax with fatty acid amide for rolled asphalt	2.0-4.0% by mass of asphalt binder	Germany	[20-30 °C]
	Licomont BS	Clariant	Fatty acid amide	3.0% by mass of asphalt binder	Germany	[20-30 °C]
	3E LT or Ecoflex	Colas	Fatty acid amide (proprietary)	Yes, but no specified	France	[30-40 °C]
Chemical Additives	Evotherm ET	MeadWestvac o	Chemical asphalt binder emulsion	Delivered in form of asphalt binder emulsion	U.S.A., France, worldwide	[50-75 °C] [*] [37-54 °C] >93 °C 85-115 °C
	Evotherm DAT	MeadWestvac o	Chemical additive plus water	30% by weight of asphalt binder	U.S.A., France, worldwide	[45-55 °C] [*] >93 °C 85-115 °C
	Evotherm 3G	MeadWestvac o	Water free chemical additive	Not Specified	U.S.A.	[33-45 °C] [*] [15-27 °C]
	CECABASE RT	CECA Arkema group	Chemical additive	0.2-0.4% by mixture weight	U.S.A., France	120 °C [*] 101 °C
	Rediset WMX	Akzo Nobel	cationic surfactants and organic additive	1.5-2% of asphalt binder weight	U.S.A., Norway	[≥30 °C] [*] [16 °C] 126 °C
	REVIX	Mathy-Ergon	Surface-active agents, waxes processing aids, polymers	Not specified	U.S.A.	[15-26 °C]
	Iterlow T	IterChimica	-	0.3-0.5% by mass of asphalt binder	Italy	120 °C

Note: - indicates data unavailable.

It can be seen from Table 1 that the number of products under the category of foaming technology is the largest, followed by the category of chemical additive and organic additive. Moreover, for the implementation extent of each category of WMA technology in the U.S.A., foaming technology is the most popular one with most products being used in the U.S.A., followed by chemical additive and organic additive. There is only one product from organic additive most used in the U.S.A., which is Sasobit.

Organic Additives

This category of technology adds waxes to the mix. The waxes are high molecular hydrocarbon chains (C45 or more) with a melting point of 176-248 °F (80-120 °C). They are capable of modifying the properties of the original asphalt binder. The temperature at which the wax melts is related to the length of the carbon chain (8). The quantity of wax added is generally 2-4% of the total mass of the binder. The temperature reduction usually attained by adding these waxes is 36-54 °F (20-30 °C) (6). In addition, waxes added into the asphalt mix improve the deformation resistance (rutting resistance) of the asphalt (9).

When the temperature rises above the melting point of waxes, its viscosity decreases (9-10). As the mixture cools, these additives solidify into microscopically small and uniformly distributed particles, thus they increase the stiffness of the binder in the same way as fiber-reinforced materials. This type of process starts being used at the end of 1980s and it has developed into three technologies, which differ in the type of wax used to reduce viscosity: Fischer-Tropsch wax, fatty acid amide, and Montan wax. These three waxes are described below (6):

Fischer-Tropsch Wax: Fischer-Tropsch (FT) waxes are synthetic waxes produced by the FT process. FT is a method for the synthesis of hydrocarbons and other aliphatic compounds from synthetic gas, which is a mixture of hydrogen and carbon monoxide in the presence of a catalyst. The hydrogen-carbon monoxide gas mixture is obtained by coal gasification or natural gas reforming (11). A FT wax is a pure hydrocarbon without functional groups, and is regarded to have high chemical stability and aging resistance. The melting point of a blended FT wax and asphalt binder is about 176-185 °F (80-85 °C), which is lower than the melting point, 212 °F (100 °C), of a pure FT wax. This allows asphalt compaction at less than 212 °F (100 °C) (12). During the cooling process, the crystallization of a FT wax begins at 221 °F (105 °C) and is completed at 149 °F (65 °C), thus forming regularly distributed, microscopic, stick-shaped particles.

The main difference between naturally occurring asphalt binder waxes and FT waxes is that FT waxes have longer chain length and finer crystalline structure. Researchers have shown that FT waxes have good oxidation and aging resistance, and can be stored for a long time (13).

Fatty Acid Amide Wax: Fatty acid amide waxes are synthetic. They are synthesized by initiating amines to react with fatty acids. The melting point of amide waxes is 284-293 °F (140-145 °C), and the solidification of amide waxes takes place at 275-293 °F (135-145 °C). Similar products of Amide waxes were first used in roofing asphalt from the late 1970s to the early 1980s and have been used as viscosity modifiers in asphalt for several years. Fatty acid amides increase asphalt stability and deformation resistance by forming crystallites in the asphalt binder during cooling (2).

Montan Wax: Montan wax (lignite wax) is a hard wax obtained by solvent extraction of certain types of lignite coal. Its composition is non-glyceride long-chain (C24-C30) carboxylic acid esters (62-68 weight %), free long-chain organic acids (22-26%), long-chain alcohols, ketones, and hydrocarbons (7-15%), and resins. Since the melting point of this wax in its pure state is approximately 167 °F (75 °C), it is often blended with materials with a higher melting point such as amide waxes. Montan waxes can be added directly into the mixer. For mastic asphalt, the addition of Montan waxes requires additional mixing time by a mobile stirrer (14-15).

The type of wax must be carefully selected in order to avoid possible temperature issues. The melting point of the wax should be higher than in-service temperatures to maintain resistant and solid. In addition, the choice of optimum amount of Montan minimizes the embrittlement of the asphalt at low temperatures (16).

Foaming Processes

This technology mainly requires the addition of small amounts of water, either injected into the hot binder or directly into the HMA mixing chamber (17). The physical properties of the asphalt binder are temporarily changed as soon as the injected water is in contact with the hot asphalt binder. The water is rapidly turned into vapor and trapped in thousands of tiny asphalt binder bubbles (18). The large volume of foam temporarily increases the volume of the binder and reduces mix viscosity. The effect of this foaming process remarkably improves the coating and workability of the mix (6). However, the foam dissipates in less than a minute and asphalt binder is assumed to resume its original properties. This means that the mix must be spread and compacted soon after production. These methods have been tested for soft and medium asphalt binder grades (19). The quantity of injected water should be just enough to produce the foaming effect, but not so much as to cause a stripping problem of the mixtures (20). The basic process is the same for most of these technologies. However, based on the way how water is added to the binder, foaming process can be divided into two technologies: (i) water-based technology, and (ii) water-containing technology (10).

Water-based Technologies: This method uses water in a direct way. The water is injected directly into the hot binder flow usually with special nozzles to produce foaming effect. As the water rapidly evaporates, this generates a large volume of foam that slowly collapses. This category can be subdivided into the two types (6, 10):

- ✧ Single component system: Nozzles are used to inject the cold water to microscopically foam the binder, such as Double Barrel Green, AQUABlack WMA, Warm Mix Asphalt System, Ultrafoam GX in Table 1.
- ✧ Double components system: WAM Foam in Table 1 is one type of this system. This is a two-component binder system, also known as a two-phase method, which adds a soft binder and a hard foamed binder at different times into the mixing cycle during production. The soft binder is first mixed with the aggregate to pre-coat it. Later the hard foamed binder is added to the mixture, which has been foamed by the previous injection of cold water in a quantity ranging from 2% to 5% of the mass of the hard binder.

Water-containing Technologies: These technologies employ synthetic zeolite to produce water for a foaming process. Zeolite is composed of aluminosilicates of alkali metals, and is hydrothermally crystallized. The crystallization contains approximately 20% water, which is released from the zeolite structure as the temperature increases. Zeolites contain large air voids, which host cations and even molecules or cation groups such as water. Aluminosilicates have the ability to lose and absorb water without damaging crystalline structure. The released water causes a micro-foaming effect in the asphalt mix, which lasts about 6-7h (2, 20-21).

Other Technologies: There are other technologies that use water differently, and therefore cannot be classified into above two categories of foaming processes. For example, there is a technology called Low Energy Asphalt described in Table 1 that uses wet fine aggregate, and such technologies are based on a process known as sequential mixing. The foaming effect is produced as the water on contact with the hot binder when aggregate of fine particle size is partially dried. Water content of this technology is often around 0.5% at 203 °F (95 °C) (2, 6, 8).

Another type of technologies is called as Low Emission Asphalt technology developed by McConnaughay in 2007 as described in Table 1. It uses combination of foaming and chemical technology and has two phases for the mixing process. The binder containing a chemical additive is added to the hot coarse aggregates in the first phase, and then wet sand is added in the second phase, which creates a foaming action (22).

Chemical Additives

Use of chemical additives does not depend on viscosity reduction or foaming for lowering mixing and compaction temperatures. Instead, they generally adopt a combination of emulsification agents, polymers, additives, and surfactants to improve coating, mixture workability, and compaction, as well as adhesion promoters (anti-stripping agents). The additive content and the temperature reduction depend on the type of chemical additives used (6).

For many WMA technologies, additional technology and necessary plant modifications are needed. The necessary modifications for WMA technologies widely used in U.S.A are summarized in Table 2.

TABLE 2 Summary of Necessary Modifications for WMA Technologies (6).

Category	Product	Form of Product Supplied by Manufacturer	Plant Modifications
Foaming Processes	Double Barrel Green (Water based)	A unit completely assembled	Installation of the unit which is suitable for both drum and batch plants.
	AQUABlack WMA (Water based)	A unit completely assembled	Installation of the unit which is suitable for both drum and batch plants.
	Warm Mix Asphalt system (Water based)	A unit completely assembled	Installation of the unit which is suitable only for drum plants.
	WAM-Foam (Water based)	A Foaming nozzle with expansion chamber, and a separate binder line	Installation of an new binder line with water addition system (nozzle with chamber) for introducing hard binder into mixture.

TABLE 2 (continued).

Category	Product	Form of Product Supplied by Manufacturer	Plant Modifications
Foaming Processes (continued)	Low Energy Asphalt (Water based)	A unit completely assembled including cold feed bin for wet fine aggregate with metering system, moisture addition and control system, in-line pump and metering system for additives, and mix phase modifications	Installation of the unit.
	Advera (Water containing)	Zeolite powder	Installation of modified fiber feeder or choice of several special equipment units offered by manufacturer.
	Aspha-min (Water containing)	Granulate and powder in Polyethylene bags and big bags of 500 and 1000kg	Weight hopper, modified fiber feeder or pneumatic feeder for introduction granulates or powder is needed.
Organic Additives	Sasobit	In a solid form either like a prill or in flaked form, which is packaged in 20 kg bags and 600 kg super sacks.	Installation of modified fiber feeder or pneumatic pump for in-line adding, or blending unit for stirring Sasobit with hot binder at terminal. Possibly change of mixing program if added in pug mill with weight hopper. No modifications if Sasobit in emulsion form.
	Evotherm ET	Asphalt emulsion	No plant modifications required. Binder content must be increased by the amount of water in the emulsion.
	Evotherm DAT	Liquid chemical additive	Storage tank for additive needed. Installation of asphalt pump with heated valves connected with binder injection line.
Chemical Additives	Evotherm 3G	Liquid chemical additive	Addition of a port to the asphalt line or weight hopper and stirring unit required for adding Evotherm 3G into liquid asphalt.
	Rediset WMX	Free flowing pastille form, packaging of 25kg or 500kg	No plant modifications required if blended with binder at refinery. Can be added to the binder with low motion stirring unit or directly into the mixer with pneumatic feeder or weight hopper.
	REVIX	-	No plant modifications required if mixed with binder at terminal. Can be added to the binder with low motion stirring unit or directly into the mixer with pneumatic feeder or weight hopper.

Note: - indicates data unavailable.

It can be seen from Table 2 that the plant modifications are needed for water based foaming processes with addition of the foaming equipment. For water containing foaming processes and organic additives such as Sasobit, plant modifications are also needed for fiber feeder or pneumatic feeder. The plant modifications with implementation of chemical additives are

minimal. Most of the chemical additives do not need any plant modifications except the addition of pump and stirring units.

Differences between WMA and HMA Design

The differences between WMA and HMA design are summarized in Table 3.

TABLE 3 Steps in Design of Dense-Graded HMA and WMA (24).

Step	Description	Major Differences of WMA from HMA
1	Gather Information	WMA technology Additive rates Planned production temperature Planned compaction temperature
2	Select Asphalt Binder	Recommended limit on high-temperature stiffness of recycled binders Consider low-temperature grade improvement when using blending charts
3	Determine Compaction Level	Same as HMA
4	Select Nominal Maximum Aggregate Size	Same as HMA
5	Determine Target VMA and Design Air Voids Value	Same as HMA
6	Calculate Target Binder Content	Lower asphalt absorption due to lower temperature
7	Calculate Aggregate Volume	Same as HMA
8	Proportion Aggregate Blends for Trial Mixtures	Same as HMA
9	Calculate Trial Mixture Proportions by Weight and Check Dust/Binder Ratio	Same as HMA
10	Evaluate and Refine Trial Mixtures	WMA technology-specific specimen fabrication procedures Lower short-term aging temperature Evaluate coating and compactability in lieu of viscosity-based mixing and compaction temperatures.
11	Compile Mix Design Report	Same as HMA

As shown in Table 3, additional adjustments is required for WMA mix design, including additional information for mix design, binder selection and content, and evaluation and refinement of trial mixtures.

Gather Information

As shown in Table 3, additional information such as WMA technology, additive rates, and planned production and compaction temperatures must be collected. Among the information, the planned production and compaction temperatures are used to replace the viscosity-based production and compaction temperatures which are applicable to HMA mix design. The optimal production and compaction temperatures of WMA should be carefully determined by insuring coating and compactability of WMA mixtures (24).

Select Asphalt Binder

Performance Grade: The same grade of binder should be used with WMA and HMA designed for the same environmental and traffic conditions, according to the recommendation of NCHRP Project 9-43 (5). The differences in the high- and low-temperature binder properties between WMA and HMA are not large enough to warrant changing the grade of the binder when WMA is used. However, it should be emphasized that it may be necessary to increase the high-temperature performance grade of the binder to meeting rutting resistance requirements, when the production temperatures of WMA processes are very low (24).

Maximum RAP Stiffness: It is appropriate to design WMA mixtures containing recycled asphalt pavement (RAP) in the same manner as HMA, considering the contribution of the RAP binder to the total binder content of the mixture. According to NCHRP Project 9-43, the RAP and new binders continue to mix at WMA process while the mix is held at elevated temperature. The difference of WMA mixtures containing RAP from HMA mixtures containing RAP is that a limit should be placed on the maximum stiffness of RAP binder for WMA to ensure adequate mixing of RAP and new binders. This limit is based on the compaction temperature of the mixture (24).

The high-temperature grade of RAP binder should be less than the compaction temperature for the WMA. It can be noted that such limit will have little effects on the use of RAP in WMA. RAP binders typically range from PG 82 to PG 100, and the corresponding minimum WMA compaction temperatures should range from 180 to 212 °F (82 to 100 °C). However, the limit restricts the use of recycled asphalt shingles (RAS) in WMA, since RAS binders have high-temperature grades exceeding 257 °F (125 °C), which results in overhigh WMA compaction temperature (24).

Blending Chart Analysis: The recovered binder data from NCHRP Project 9-43 confirmed that binders from WMA mixtures have improved low-temperature properties. This is probably due to the lesser amount of aging that occurs during production at lower temperatures. Although the improvement in low-temperature properties is not large enough to warrant changing the low-temperature grade, the improvement is large enough to affect the amount of RAP that can be added to a mixture for the use of blending chart analyses. NCHRP Project 9-43 concluded that the low-temperature grade of the binder at WMA process changes approximately 0.6 °C for every 10% of the total binder in the mixture replaced by RAP binder. This would allow 10% additional RAP binder to be added to the WMA mixture due to improving the low-temperature properties of the virgin binder in the mixture by lowering the production temperature. The benefit of more RAP incorporation into WMA mixtures without changing the grade of the virgin binder may be significant in some areas of the United States (24).

Calculate Target Binder Content

Asphalt absorption is somewhat lower in WMA (25). Based on the study of NCHRP Project 9-43, the volume of binder absorbed in WMA mixtures is 45% of the volume of water absorbed by the aggregates used in the mixture compared to 50% of the water absorption for HMA. Thus, this was recommended to be used as the initial estimate binder absorption in WMA (24).

The study by NCHRP Project 9-43 affirms the optimum asphalt content can be determined with standard HMA design procedures without the addition of the warm mix additive (5). Nevertheless, some researchers considered the optimum asphalt content can be reduced in half a percentage point below that of a reference HMA because of the enhanced compaction achieved by WMA technologies (21). On the other hand, a reduction of the optimum asphalt content may negate the improved compaction resulting from the addition of WMA additives (13).

Evaluate and Refine Trial Mixtures

The steps for WMA and HMA trial specimen preparation are summarized in Table 4.

TABLE 4 Comparison of Trial Specimen Fabrication Procedures for WMA and HMA Design (24).

Step	Description	WMA	HMA	Differences between WMA and HMA
1	Calculate batch weights	X	X	Must calculate WMA additive content
2	Batch aggregates	X	X	Must batch WMA additive for some processes
3	Heat aggregates and asphalt binder	X	X	Use planned production temperature for WMA
4	Mix aggregates and binder	X	X	Procedure is WMA process specific
5	Short-term oven conditioning	X	X	WMA uses lower temperature
6	Compact laboratory specimens	X	X	WMA uses lower temperature
7	Calculate volumetric composition of laboratory specimens	X	X	
8	Adjust aggregate proportions to meet volumetric requirements	X	X	
9	Evaluate coating and compactability	X	NA	Used in WMA design in place of viscosity-based mixing and compaction temperatures
10	Conduct performance testing	X	X	Moisture susceptibility for all mixtures, rutting resistance for design traffic levels of 3 m ESALs or greater

For WMA trial specimen preparation, the additive content needed for WMA production is specified by the WMA technology supplier as percent by weight of binder or total mixture. In addition, Viscosity-based mixing and compaction temperatures cannot be used with the most currently available WMA technologies. Instead, laboratory specimens are mixed at the planned production and compaction temperatures. Coating is evaluated to determine the acceptability of the WMA technology and process, and then a compactability evaluation should be conducted to ensure that the mixture is compactable at the planned compaction temperature (24).

Process-Specific Specimen Fabrication Procedures: Once mixing is complete, specimen fabrication for all technologies continues with short-term conditioning and specimen compaction. These steps are the same for all technologies and the same as done with HMA. According to NCHRP Project 9-43, planetary mixers are more efficient than bucket mixers. For WMA technologies with the additive blended in the binder, a mechanical stirrer is needed. For

designing mixtures for plant foaming processes, a laboratory foamer is required, which can produce foamed asphalt at the moisture content used by the field equipment (24).

Short-Term Conditioning: Short-term conditioning for WMA is needed for the volumetric design and for the moisture susceptibility and rutting evaluation. WMA should be conditioned for 2 hours at the planned compaction temperature to simulate the absorption and binder stiffening that occurs during construction. The condition selection depends on comparisons of properties of laboratory-mixed, laboratory-compacted specimens with those field-mixed, field-compacted specimens (24).

Additional research on short-term conditioning for performance evaluations, moisture susceptibility, and rutting resistance was recommended by NCHRP Project 9-43.

WMA Evaluations: Four evaluations should be conducted on WMA mixtures at the design binder content: (i) coating, (ii) compactability, (iii) moisture susceptibility, and (iv) rutting resistance (24). Comparing with HMA design, WMA design needs an evaluation of coating and compactability at planned production and compaction temperatures.

Coating: Coating is recommended by NCHRP Project 9-43 to be evaluated on WMA mixtures using AASHTO T 195, *Standard Method of Test for Determining Degree of Particle Coating of Bituminous-Aggregate Mixtures*, which counts the percentage of the coarse aggregates in the mixture that are fully coated (24).

Compactability: The compactability evaluation for WMA is used instead of the viscosity-based mixing temperature used for HMA. Compactability is evaluated by compacting specimens to N_{design} gyrations at field compaction temperature and again compacting duplicate specimens to N_{design} gyrations at 54 °F (30 °C) below the field compaction temperature. The number of gyrations to reach 92% relative density is then calculated from the height of the evaluated specimen. The ratio of the gyrations to 92% relative density at the lower temperature to the higher temperature is determined as compactability. The acceptable compactability should be less than or equal to 1.25 (24).

Moisture Susceptibility: Moisture susceptibility of WMA can be evaluated using AASHTO T 283, the same as HMA. Results of NCHRP Project 9-43's study showed that the moisture susceptibility of WMA mixtures would be different from HMA mixtures designed using the same aggregates and binder. Indeed, the tensile strength ratio of some of the WMA mixtures were improved by including anti-stripping additives during WMA processes. For WMA mixtures produced without anti-stripping additives, the tensile strength ratio never improved but even decreased (24).

Rutting Resistance: Rutting resistance is recommended by NCHRP Project 9-43 to be evaluated using the flow number test, AASHTO TP 79, *Determining the Dynamic Modulus and Flow Number of Hot Mix Asphalt (HMA)* with the same testing conditions used for HMA (24).

It should be noticed that additional research is needed to develop a short-term conditioning procedure for specimens used for the evaluation of moisture susceptibility and rutting resistance, which is equally applicable to both WMA and HMA. A two-step conditioning process should be

considered. The first step is to simulate the binder absorption and stiffening that occurs during construction, in which the mixture would be conditioned for 2 hours at the compaction temperature. The mixture would be further conditioned in the second step for an extended time at a representative high in-service pavement temperature for the purpose of simulating a short period of time in service. The second conditioning step would be only used for specimens that need to be evaluated by moisture susceptibility and rutting resistance. The first step would be only used for volumetric mix design (24).

Laydown and Compaction Differences between WMA and HMA

Reports from contractors in both Europe and the United States specify that the laydown and compaction of WMA is not different from the way of laydown and compaction of HMA, with the exception of the temperature at which these operations occur. Paving contractors believe that WMA technologies can help contractors achieve a more uniform compaction, since the lower operating temperatures of these technologies allow the roller train to have better spacing and ensure proper mat coverage. Compared to HMA, WMA is easy to achieve minimum density (26-27).

Advantages and Disadvantages of WMA

Advantages

Although different WMA technologies may have different benefits, WMA appears to be driven by four major benefits associated with its use (3, 6, 9, 28):

1. Environmental benefits: lower plant emissions during production and fumes during construction, recycling scrap tires;
2. Economic benefits: Reduced energy consumption, which lowers fuel use and production costs;
3. Pavement benefits: reduced mixture viscosity, which can improve workability and compaction efficiency, longer haul distances, and quicker turnover to traffic due to shorter cooling time; and
4. Production benefits: Increased RAP content in WMA mixtures and location of plant site in urban areas.

Environmental Benefits: Measurements show that pollutant emissions during WMA production are even lower than those during HMA production (29-31). The reason is that emissions are related to temperature according to the data from Bitumen Forum: “At temperatures below 80 °C, there are virtually no emissions of bitumen; even at about 150 °C, emissions are only about 1 mg/h. Significant emissions were recorded at 180 °C” (2).

Furthermore, the reduction of emissions and fumes benefits workers, who are dangerously exposed to the fumes produced by asphalt paving process (32). In addition, the lower mix temperatures also provide a more comfortable working environment, and this might even be a factor that maintains workers for a longer time at their jobs (6).

Also, this kind of mixtures makes the addition of crumb rubber possible (33). Consequently, we can develop rubberized asphalt mixtures with lower mixing and compaction temperatures, and longer long-term performance of the pavement when compared with conventional asphalt pavement (6).

Economic Benefits: According to other studies, there was typically a 20% to 75% energy consumption reduction for a WMA technology compared with regular HMA production, depending on how much the production temperatures were lowered. The significance of this benefit is determined by the type and cost of energy. This benefit can be a significant motivation to implement WMA technologies in areas where energy cost is relatively high, whereas this benefit is less of a motivation in areas where costs are relatively low (3).

Paving Benefits: Although the effects of WMA technologies on viscosity vary to a certain extent, reduced mix viscosity can enhance the workability and compaction of the mix. Research data shows that these technologies act as compaction aids which can reduce the compactive effort required (34). Other research also proves that WMA has a greater level of consistency regarding surface temperature for more even compaction. However, traditional HMA has an inconsistent surface temperature, which can lead to compaction issues (35).

Because the mix temperature is closer to ambient temperature, it is possible to pave in cold weather (6). This benefit extends the paving season. It is also practicable to haul longer distance. Therefore, plant sites can be located at greater distances from road construction sites (36).

Moreover, lower temperature makes road construction and road opening times shorter. This is especially desirable in certain circumstances such as airport rehabilitations, high-traffic city roads, and so on. (14-15).

Production Benefits: The main benefit of this part is the potential of greater use of RAP because of the increased workability of WMA mixes (5, 37). With the same benefits for HMA pavements, the uses of RAP in WMA pavements can help to offset increased initial costs, conserve natural resources, and avoid disposal problems (6). In addition, a lower production temperature, which is due to the improved workability, leads to less aging of binder. This counteracts the aging effect of stiffer RAP binder.

Another benefit for production is directly related to the reduced emission of fumes, is the possibility of locating plant sites in urban areas (32).

Disadvantages

Each WMA technology also has different flaws and should be analyzed separately. The main concerns about drawbacks of WMA are the performance and implementation of WMA, especially in reference to specifications and quality controls (6). The issues are as following discussions.

Rutting: Permanent deformation (rutting) of the pavement surface is mainly caused by the less aging of the binder because of the lower production temperatures, as well as moisture susceptibility of WMA mixes (6, 10, 38).

Cost Effectiveness: Initial costs and other costs, such as recurrent costs or royalties, could discourage contractors. WMA is an option only if it costs the same as or less than conventional HMA. Otherwise, a moderate increase in cost would be acceptable unless either environmental regulations are made stricter or it provides some quality or construction benefits (3). These WMA technologies could bring important savings if a better long-term performance is achieved (6). However, this has not been proven because WMA pavements have not been put into service for a sufficiently long time period for a real evaluation of their cost effectiveness (39). Neither laboratory long term performance tests were conducted.

Moisture Susceptibility: Lower mixing and compaction temperatures can lead to incomplete drying of the aggregate. Thus, the low mixing and compaction temperatures used during WMA production may increase the potential for moisture damage (13, 40-41). Although anti-stripping additives are used in WMA, these additives may chemically react with asphalt binder, aggregate, and the water-bearing additive at a temperature around 230 °F (110 °C) and may cause a loss of bond in a mixture, which lead to moisture damage (6).

Long-term Performance: The relative newness of WMA products results in few field test sections in number and short life of WMA pavements (ten years in the U.S.A. and over ten years in certain European countries) (6). Therefore, WMA was employed without knowing the long term performances. Although reports about WMA performance in both the U.S.A. and Europe are positive so far, it is possible that WMA may not perform well throughout its life cycle. (6, 14, 21). Specifically, how RAP of WMA will perform and what will be WMA-RAP quality and life cycle.

Environmental Pollution Effects of WMA Additives: It is still uncertain whether the use of chemical additives of certain WMA technologies is a potential source of pollution (6).

STATE DOT, NCHRP, SHRP, UTC, AND FHWA REVIEW

Evaluation of Additives

Washington State Department of Transportation (DOT) examined four WMA projects with four different technologies which include one organic additive: Sasobit and three water foaming technologies: Gencor Green Machine Ultrafoam GX, AQUABlack, and water injection. The comparison between different technologies indicated following conclusions from field compaction and laboratory performance of mixtures (42):

- For field compaction, the AQUABlack WMA section had a higher density than the HMA control. Other WMA technologies showed no evident difference in density with their HMA counterparts. The AQUABlack and water injection WMA mixtures presented statistically lower air void contents than the HMA control mixtures after pavements were open to traffic, indicating these mixtures may be more solid than the HMA control mixtures.
- The Sasobit, Gencor, and water injection mixtures were comparable to their HMA control mixture counterparts in terms of stiffness (42). The AQUABlack mixtures had a lower

stiffness value than the HMA control mixtures.

- For fatigue resistance, the water-based forming WMA mixtures showed similar fatigue resistance to the HMA control mixtures. However, the Sasobit mixture showed less fatigue resistance than the HMA control mixtures.
- For thermal cracking, Gencor and water injection mixeturs showed more resistance to thermal cracking than their HMA control mixtures, whereas the thermal cracking resistances of Sasobit and AQUABlack mixeturs were comparable to their HMA control mixtures.
- For rutting resistance, the Sasobit and AQUABlack mixtures showed similar rutting resistance to the HMA control mixtures. However, the Gencor and water injection mixtures indicated less resistance to rutting than the HMA control mixtures.
- For moisture susceptibility, all the WMA and HMA control mixtures performed similarly.

National Center for Asphalt Technology (NCAT) at Auburn University conducted several researches to evaluate one organic additive called Sasobit, one foaming process called Aspha-min (a water-containing zeolite), and one chemical additive called Evotherm ET. From their studies, the conclusions are as following (14, 40-41):

- All three of these additives improved the compactability of the mixtures in both Superpave Gyratory Compactor (SGC) and the vibratory compactor. The addition of Evotherm reduced the air voids most, followed by Sasobit and then Aspha-min.
- The addition of Evotherm increased the resilient modulus of WMA mixtures. However, the addition of Sasobit and Aspha-min did not affect the resilient modulus of WMA mixtures.
- The addition of Evotherm significantly decreased the rutting potential of the WMA mixtures compared to HMA control mixtures. Similar to Evotherm, the Sasobit decreased the rutting potential of the WMA mixtures evaluated. However, the addition of Aspha-min did not increase the rutting potential of WMA mixtures. The mixtures containing Evotherm and Saosibit were not sensitive to the decreased production temperatures in terms of rutting (14, 41).
- The indirect tensile strengths were lower for WMA mixtures, in some cases, containing Sasobit, Aspha-min, and Evotherm, and there was no differing strength gain with time for the mixtures containing these additives. In addition, the reduction in tensile strength is believed due to the anti-aging properties of Sasobit. A suggestion was made that the addition of Sasobit and Aspha-min may not require a cure time for the asphalt mixture prior to opening to traffic (14, 40).
- All three additives may increase the potential of moisture damage due to the lower mixing and compaction temperature used when producing WMA. This effect is caused by incomplete drying of aggregate.

- Various anti-stripping agents were evaluated to moderate the potential of moisture damage. The addition of AKZNobel Magnabond (Kling Beta 2912) improved the tensile strength ratio (TSR) values to acceptable levels for the Sasobit additive. Hydrated lime used with Aspha-min appeared to be effective with the granite aggregate and resulted in improved cohesion and moisture resistance (43).
- Hamburg Wheel Tracking tests indicated good performance in terms of moisture susceptibility in mixtures containing Sasobit and Magnabond. Hamburg results also suggested the lime will assist in the rutting resistance of warm mixtures with Aspha-min compacted at lower temperatures due to the lime stiffening the asphalt binder (43).

From the studies above, a conclusion can be made that it is difficult to decide which additive or warm mix technology is better than others. The concerns about how to select right warm mix technology need to be measured by many factors, such as local environment, economic condition and material available around construction location, etc.

WMA Mix Design Method

NCHRP Report 691 (NCHRP Project 9-43), *Mix Design Practices for Warm Mix Asphalt*, recommended mix design methods for WMA (5). These recommendations for WMA mix design practices are included in AASHTO R35 as a draft appendix, “Special Mixture Design Considerations and Methods for Warm Mix Asphalt (WMA).” The conclusions from NCHRP study can be summarized as following: the HMA mix design results can be applied to WMA for an HMA mixture with 1% binder absorption or less. The WMA specimens should still be evaluated for coating, compactability, rutting, and moisture susceptibility, since these performance properties of WMA may be different from those of HMA. Compactability was found to be diverse based on the WMA technology used as well as the production temperature, especially for mixtures containing RAP. In general, WMA mixtures are more susceptible to moisture damage than HMA mixtures, so an anti-stripping additive should be considered in the mix design. Besides, WMA technologies with very low production temperatures may cause the produced WMA mixtures exhibiting less resistant to rutting than HMA mixtures. In brief, a WMA mixture produced with the same aggregate and binder as a HMA mixture will have similar properties regarding volumetrics. However, stiffness value from laboratory-compacted specimens of the WMA mixture after short term aging is lower than that of the HMA mixture (42).

Washington State DOT reports that aggregate gradations typically used for HMA currently have been found to be adequate for use in WMA (13, 40, 44). For RAP addition, WMA mix design can consider high contents of RAP incorporation due to less aging of virgin asphalt, whereas HMA mix design have a difficulty with high percentages of RAP incorporation because of the severely aged binder present in RAP (45). However, the PG grade will change with incorporating more than 20% RAP in WMA a mix and further binder testing will be needed to determine the PG of the blended binder. Furthermore, other factors, especially at lower mixing temperature, such as variability of RAP and the degree of blending between virgin binder and RAP binder, also affect the performance of the mix (42). Washington State DOT allows the substitution of up to 20% RAP incorporation without the use of blending charts for WMA (46).

WMA Pavement Performance

Michigan DOT constructed a field trial of Sasobit WMA pavement (organic additive). Superpave mix design was used. Mixing temperatures for the WMA and HMA control mixes were 260 °F and 325 °F (127 °C and 163 °C), respectively. The compaction temperatures for the WMA test section and HMA control section were 250 °F and 300 °F (121 °C and 149 °C), respectively. Based on the laboratory and field testing, the WMA technology performed equal to and even better than the control mixture (47).

Colorado DOT studied WMA technologies including Advera (water containing foaming process), Sasobit (organic additive), and Evotherm (chemical additive). The design method for these WMA pavements used the same mix designs for the WMA mixtures and HMA control mixtures. The target mixing and compaction temperatures for both the Advera WMA mixture and Sasobit WMA mixture were 255 °F and 235 °F (124 °C and 113 °C), respectively. For the Evotherm WMA mixture, the target mixing and compaction temperatures were 250 °F and 230 °F (121 °C and 110 °C). After three years of field evaluations, the field performance was excellent. The performance of the WMA test sections were comparable to the HMA control sections in regards to rutting, cracking, and raveling (48).

NCAT evaluated the WMA project with 20% RAP in Walla Walla, Washington. The WMA was produced using AQUABlack WMA system which is a type of water based foaming process. The mix design used for the HMA was also used for the WMA without any changes. Production temperature for the WMA was approximately 275 °F (135 °C), and for the HMA control, production temperature was approximately 325 °F (163 °C). Compaction temperature was 300 °F (149 °C) for the HMA specimens and 250 °F (121 °C) for the WMA specimens. After 13 months in service, the HMA and WMA sections exhibited similar field performance and tests on cores taken from the WMA and HMA pavements had very similar results (46).

Nebraska Department DOT used three WMA technologies, including Evotherm (chemical additive), Advera (water containing foaming process), and Sasobit (organic additive). The Superpave method of mix design was used. All WMA mixtures were produced at around 275 °F (135°C) compared to 329 °F (165°C) of HMA control mixtures. The WMA mixtures were compacted at around 255 °F (124 °C) comparing to 275 °F (135 °C) of HMA control mixtures in the field. After two years in the field, both the WMA and HMA have performed well (49).

Texas DOT studied the WMA in Texas using three technologies, Evotherm (chemical additive), Advera (water containing foaming process), and Sasobit (organic additive). Standard TxDOT mixing and compaction temperatures were used for the HMA mixtures as well as for the WMA mixtures: 325/300 °F (163 °C/149 °C) for PG 76-22 and 290/250 °F (143 °C/121 °C) for PG 64-22. In addition, WMA mixtures were designed at 30 °F (17 °C) below standard and at 60 °F (33 °F) below standard. Laboratory tests showed that WMA was initially less stiff than HMA control mix but stiffened significantly during the first year in service. Stiffness of WMA also increases in laboratory oven curing time and temperature. Field evaluation of WMA indicated similar performance to HMA. Testing of X-ray CT in the laboratory and ground penetrating radar (GPR) in the field pointed out the uniformity of WMA construction might be better than that for hot mix construction (50).

Laboratory Test Procedures

NCHRP Report 691 (NCHRP Project 9-43) stated the required performance testing for WMA (5). Evaluation of the coating, compactability, moisture susceptibility and rutting resistance of the design mixture for WMA are mandatory as discussed above.

Optional mixture analysis tests are also recommended by the NCHRP Report 691, including the evaluations of dynamic modulus, resistance to fatigue cracking, and resistance to thermal cracking (5).

As the same as HMA specimens, WMA specimens are sometimes reheated for performance testing. The study of NCHRP 691 indicated that reheating WMA specimens changes their stiffness values. Specimens were tested for stiffness by determining their dynamic modulus values before being reheated, after being reheated and after a delayed period of time after compaction without being reheated. This is to determine if reheating has the same effect on WMA as HMA. The result showed that reheated specimens were stiffer for both WMA and HMA. The specimens that were compacted and tested after a storage period without being reheated exhibited slightly increased stiffness values as well. As a conclusion, reheating WMA specimens is acceptable because of the similar effect of reheating to HMA specimens. The NCHRP 691 study provided the suggestion that reheating times and temperatures should be minimized to reduce the effect of additional aging on the specimens (5, 42).

THIS PAGE LEFT BLANK INTENTIONALLY

WMA TECHNOLOGIES IMPLEMENTED IN NEW MEXICO

Two WMA technologies currently used in New Mexico are (i) water based foaming process and chemical additive. The water based foaming processes include three technologies: (a) Double-Barrel Green (Astec), (b) AQUABlack WMA (MAXAM Equipment), and (c) Warm Mix Asphalt System (Terex). These technologies use nozzles to inject water into asphalt binder stream but different equipment developed by the individual company. Only one type of chemical additive that is used in New Mexico is Evotherm. The description of these specific products is listed as follows.

WATER INJECTION FOAMING PROCESSES USED IN NEW MEXICO

Double Barrel Green

Double Barrel Green is manufactured by Astec Green Pac. It has components like a skid-mounted corrosion-free water reservoir, and a Programmable Logic Controller (PLC) control water addition system with foaming nozzles. It can be used with both drum mix and batch plants (51). Figure 2 illustrates the nozzle of water addition system. It can be seen that the foamed asphalt concrete (AC) is generated when water is injected into the AC chamber and only liquid AC flows out from the system when the water valve is closed. Figure 3 illustrates the Double Barrel Green foaming process system. The green part is the compact and can be added to any Double Barrel mixer.

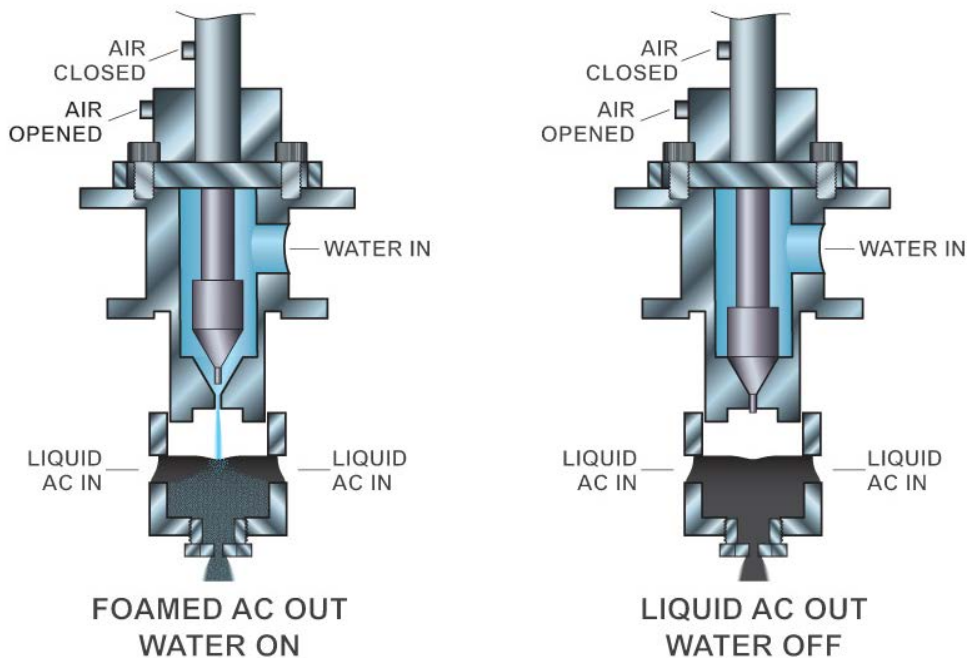

FIGURE 2 WMA System Nozzle of Double Barrel Green (51).

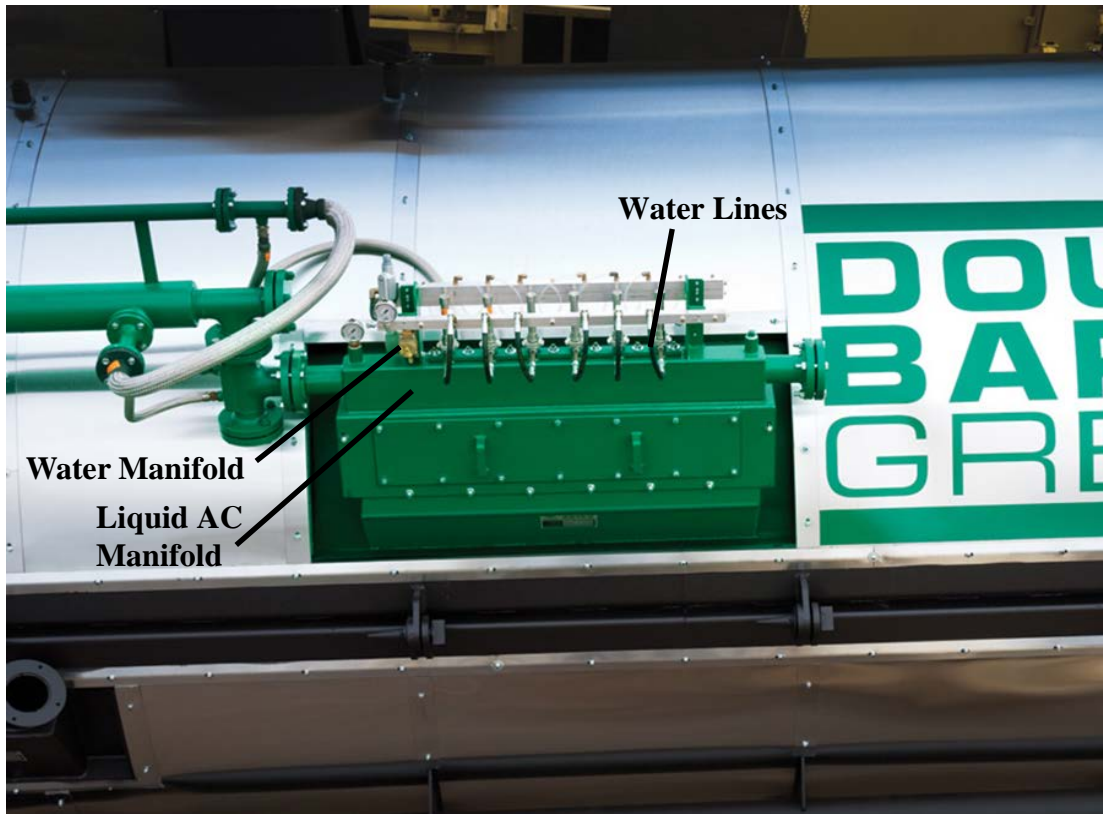

FIGURE 3 Astec Double Barrel Green System (51).

AQUABlack WMA

This technology is manufactured by MAXAM Equipment. It can be used with any asphalt plant. Components include a PLC based touch screen control panel to control the amount of water injection, a high-pressure variable speed metering system, and an AQUABlack foaming gun. It uses just one center convergence nozzle from stainless steel and provides high-pressure system (1000 psi operating pressure), that enables low water-to-liquid-asphalt ratio during foaming and create microbubbles which stay in the mix until compaction. Figure 4 shows the AQUABlack WMA system installation unit and water injection chamber (8, 52).



(a) AQUABlack Unit



(b) Water Injection Chamber

FIGURE 4 AQUABlack WMA System (52).

Warm Mix Asphalt System

This system can be used only with drum plants. The components of this system include a PLC control system to control asphalt AC-to-water mix ration, a water tank skid with tank, filter, water pump, water meter, and calibration valve, solenoid valves to control flow of water, a patented foam expansion chamber. The foamed binder is produced just outside of the drum in an expansion chamber and immediately injected into the drums' mixing chamber to coat the aggregates (8, 53). Figure 5 illustrates the Terex WMA system. The big tank in Figure 5 is the water tank skid.



FIGURE 5 Terex WMA System (53).

CHEMICAL TECHNOLOGY USED IN NEW MEXICO – EVOTHERM

Figure 6 illustrates the chemical process of evotherm. It can be seen that evotherm package stored in the tank is connected to a volumetric pump which is connected with the asphalt line injection point (54). Evotherm is produced from natural tree oil and works as surfactants which are surface active agents with molecules that possess both nonpolar and polar qualities. When evotherm is introduced into the mixing process of asphalt and aggregate, the heat energy needed to adequately coat asphalt and aggregate are partly replaced with chemical energy, thus the mixing temperature is reduced. During mixing, the evotherm molecules go to the interface of asphalt and aggregate, where the polar heads of evotherm molecules attract the polar properties in the aggregates and the nonpolar tails of evotherm attract the nonpolar asphalt oil. In addition, if any polar water molecules present in the mix, it will be captured into the micelles composed by evotherm molecules. After mixing, the excess evotherm molecules for coating form micelles with very low viscosity that offers no resistance to shear stress and with dynamic properties that allow deformation and shape change and stay intact. During compaction, these evotherm micelles work as slip planes that allow the asphalt and aggregate slip pass each other and compact into a very solid surface at low temperatures. Evotherm WMA technology can be used in any traditional HMA application from the binder course to the surface course. This unique technology currently allows asphalt application at a temperature that is 60 to 90 °F (33 to 50 °C) lower than HMA paving. There are no equipment changes at the plant or job site required by evotherm WMA technology. Evotherm just can be metered into existing materials and dropped into existing HMA job mix formulas. The workability and compactability of evotherm WMA mixes at reduced temperatures are easier than HMA, especially for coarse mixes and polymer modified asphalt binders (55).

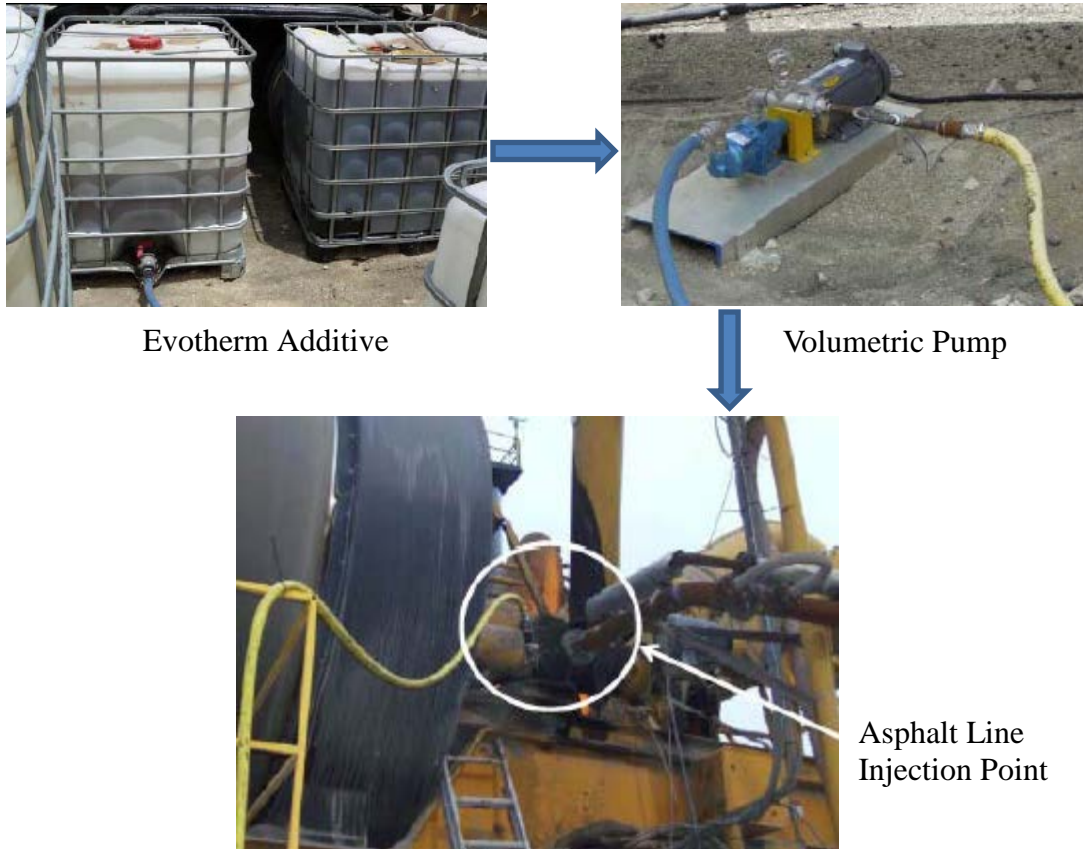

FIGURE 6 Chemical Process of Evotherm Package (55).

There are three technologies produced by MeadWestvaco. They are: (i) Evotherm ET also known as Evotherm), (ii) Evotherm DAT, and (iii) Evotherm 3G (7).

Evotherm ET

This is an emulsion technology, which uses a chemical additive of emulsification agents and anti-stripping agent additives to improve aggregate coating, mixture workability and compaction. Base binder is first converted into a high-residue asphalt emulsion (70% binder residue, 30% emulsion) in an emulsion plant. Evotherm ET added at 30 percent mass of the binder can decrease the viscosity of the binder at lower mixing temperatures, which leads to fully coated aggregates at the same temperature. In addition, different chemical additives are available for different aggregate types with different adhesion agents. When the emulsion contained binder and Evotherm ET is mixed with aggregates, the majority of water in the emulsion flashes off as steam. The process can reduce the production temperature by 30 percent (2, 56).

Evotherm DAT

This is a dispersed asphalt technology, which is the same chemical additive as Evotherm ET diluted with a small amount of water. Evotherm DAT is injected into the asphalt line just before the mixing chamber in the plant. It can decrease the viscosity of the binder at lower mixing

temperature, which results in fully coated aggregates. The production temperature can be reduced by 30 percent (7).

Evotherm 3G

It is in a water-free form that can be blended directly with the asphalt binder at the terminal or directly injected into the asphalt line at the plant. The 3G additive does not change the viscosity of the asphalt binder. It works in the mix by reducing the internal friction and allowing the binder to act like it works at a higher temperature (57). It can reduce production temperature by 65-85 °F (36-47 °C) than HMA (58).

THIS PAGE LEFT BLANK INTENTIONALLY

PRELIMINARY SURVEY OF NMDOT'S WMA PROJECTS

GENERAL NMDOT'S WMA PROJECTS

The WMA projects of New Mexico Department of Transportation (NMDOT) started from 2011. The statistics of all the WMA projects in New Mexico are listed in Table 5.

TABLE 5 Summary of WMA Projects in New Mexico.

Year	District	Project Number	Highway	Begining MP	Endin g MP	WMA Technology	Company	RAP Percent
2011	3	A300370	I-25	229.249	232	Evotherm	MeadWestvaco	25%
	6	6100430	NM 264	10.6	13.1	Evotherm	MeadWestvaco	0%
2012	1	1C00002	I-10	15.45	20	Foaming	Astec	34%
	1	1100530	I-10	108	116.02	Foaming	Astec	10%
	1	1100670	US 180	142.5	160.7	Foaming	Astec	35%
	1	1C00003	I-25	71.9	89	Foaming	Astec	35%
	1	1C00001	I-25	131	140	Foaming	Astec	25%
	4	4C00001	I-40	335	340.65	Foaming	Astec	0%
	6	6100510	NM 118	24.5	27	Evotherm	MeadWestvaco	0%
	6	6100450	US 60	73	76	Foaming	Astec	0%
2013	1	E100030	NM 136	-	-	Foaming	Astec	33%
	1	1100320	US 70	145.3	148	Foaming	MAXAM Equipment	35%
	1	1100550R	US 70	0	15	Foaming	MAXAM Equipment	25%
	1	E100030	-	-	-	Foaming	Astec	30%
	1	1100320	US 70	145.3	148	Foaming	Astec	33%
	1	1100320	US 70	145.3	148	Foaming	Astec	30%
	2	2100790	US 380	161.789	178.5	Foaming	Astec	33%
	2	2100170	US 82	92.54	95.07	Evotherm	MeadWestvaco	28%
	2	2100650	NM 200	3.65	8.38	Foaming	MeadWestvaco	35%
	2	2100880	US 380	178.5	190.8	Foaming	Astec	33%
	2	2101060	US 70/380	301.9	325.6	Foaming	Astec	35%
	2	2100170	US 82	92.54	95.07	Foaming	Astec	35%
	2	2100200	NM 48	0	3.356	Foaming	MAXAM Equipment	25%
	2	2100220	US 70/380	301.9	325.6	Foaming	Astec	35%
	4	4100670	I-40	355	359.5	Foaming	Terex	0%
4	4100660	I-40	-	-	Foaming	MAXAM Equipment	0%	
5	5100700	NM 371	61	72.7	Foaming	Terex	30%	
5	5100760	US 64	24.5	26.5	Foaming	Terex	30%	

Note: - indicates data unavailable.

It can be noted that like Texas and many other states, New Mexico has started 100% WMA pavement projects in 2011. From Table 5, it can be seen that, in 2011 only two WMA projects were conducted in New Mexico. Both of them are evotherm. In 2012, seven foaming WMA

projects using Double Barrel Green from Astec and one evotherm WMA project were constructed. The WMA projects began to increase from 2012 onwards. In 2013, 18 foaming projects were constructed. Foaming products such as AQUABlack WMA from MAXAM Equipment and Warm Mix Asphalt System from Terex are introduced into New Mexico.

PROJECT SELECTION

In collaboration with the Project Technical Panel, seven WMA projects in New Mexico were selected and evaluated in this study to understand the differences between WMA technologies and conventional HMA technology. The seven pavements included for this study are only 1 to 3 year old.

All these WMA projects were selected from NMDOT’s major rehabilitation projects. The roadway and technology information of these seven WMA projects are listed in Table 6.

TABLE 6 Basic Information of the Seven Selected WMA Projects.

Construction Date	District	Project Number	Highway	Beginning MP	Ending MP	WMA Technology	Manufacturer/ Company	% RAP
Aug. 2011	3	A300370	I 25	229.249	232	Evotherm	MeadWestvaco	25%
May 2011	6	CN 6100430	NM 264	10.6	13.1	Evotherm	MeadWestvaco	0%
May 2012	6	6100510	NM 118	24.5	27.0	Evotherm	MeadWestvaco	0%
Jul. 2013	6	6100451	US 60	69	73	Evotherm	MeadWestVaco	0%
Jun. 2013	2	2100200	NM 48	0.000	3.356	Foaming	MAXAM Equipment	25%
Apr. 2013	4	4100670	I 40	355.0	359.5	Foaming	Terex	0%
Jul. 2012	6	6100450	US 60	73	76	Foaming	Astec	0%
Aug. 2011	3	A300370	I 25	229.249	232	HMA Control	—	25%

Note: — indicates data not applicable.

It can be seen from Table 6 that all the WMA projects selected from 2011 to 2013. Both route directions were selected for evaluation. All the seven WMA projects were constructed in both route directions except the project on interstate I-25, which was constructed by WMA technology in the northbound direction. The southbound direction of I-25 was constructed by HMA, which is used here as HMA control section. Form the last column of Table 6, it can be seen 0% and 25% RAP were considered for each of foaming and evotherm project. The geographic locations of the WMA projects are shown in Figure 7 with NMDOT’s six districts’ boundaries.

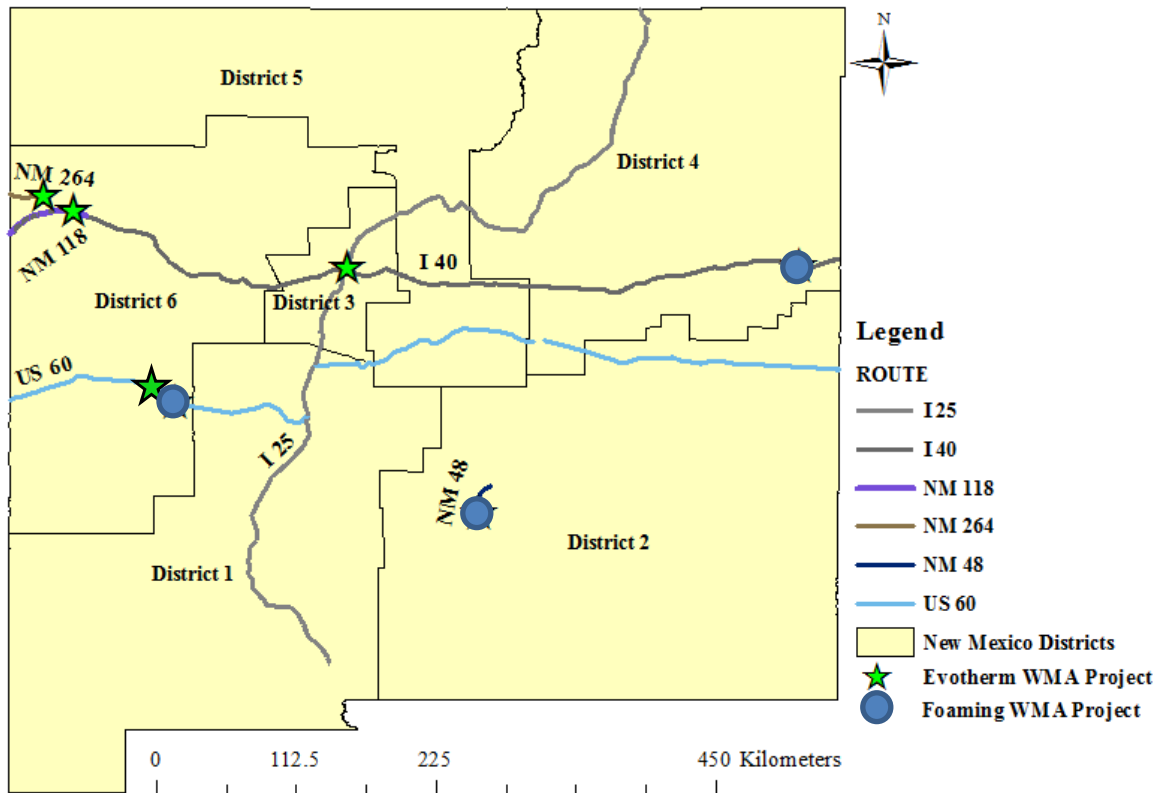

FIGURE 7 Selected Seven WMA projects in New Mexico.

PRELIMINARY SURVEY

A questionnaire survey form was developed and sent to the project managers of NMDOT and paving contractors associated with the seven selected projects, which is attached in Appendix A. The survey is used to gather WMA project information and understand the mix design, pavement construction, pavement performance, etc. for WMA implemented in New Mexico.

There is only one paving contractor (Fisher Sand & Gravel Co.) who sent back the survey responses about the WMA projects on I-25 and I-40, after all the survey forms distributed. There are two project managers also answered some questions about the survey associated with WMA project on NM 48 and I-25. All the responses are attached in Appendix B.

Responses from Project Managers

Question 1: What are the differences between WMA and HMA mix design, do you think?

Response 1: Project managers reported that the differences between WMA and HMA mix design is easier handling for WMA and lower mixing, molding, and laydown temperatures.

Question 2: What are the differences between WMA and HMA pavement construction (such as pavement compactability, environmental benefits, length of construction season, haul distance, times of road construction and opening)?

Response 2: The differences between WMA and HMA pavement construction is believed that WMA can be compacted easier and there will be some environmental benefits and cost saving in fuel from WMA projects for contractors.

Question 3: What are the differences of QA/QC data between WMA and HMA projects, do you think? What is differently done about the QA/QC of WMA project?

Response 3: The differences of QA/QC data between WMA and HMA projects are reported that the material was tested exactly the same and evaluated the same.

Question 4: Are there some advantages or disadvantages of combining RAP and WMA, comparing with RAP and HMA (such as the amount of RAP used, any effects)?

Response 4: For the RAP used in WMA, there is a concern with proper RAP mixing at lower WMA temperature.

Question 5: How are the pavements with WMA performing of your projects, any distress (cracking, deformation, deterioration and mat problems)?

Response 5: For the performance of WMA pavements, it is reported that the pavements are performing well so far.

Question 6: Why do the pavements (in your answer (a) above) perform (good or bad) as they do, what do you think caused the pavement distress (mix design, construction, materials, climate, traffic, structural design and geometric design)?

Response 6: For the causes of bad performance pavement, one reported reason is traffic and materials used especially concern with RAP.

Responses from Paving Contractors

Question 1: What are the differences between WMA and HMA mix design, do you think?

Response 1: The differences between WMA and HMA mix design are believed depending upon the WMA technology used. For additives, there are no changes required by current NMDOT mix design practices or requirements. For Foaming process, it is beneficial to have a laboratory foamer to utilize during the mix design process so that the designer has a better understanding of how the mix may react during production.

Question 2: What are the differences between WMA and HMA pavement construction (such as pavement compactability, environmental benefits, length of construction season, haul distance, times of road construction and opening)?

Response 2: The differences between WMA and HMA pavement construction are reported that WMA pavements are easier to obtain in-place density over traditional HMA. The burner fuel consumption was also reported to be reduced by roughly 30%. The WMA also tends to remain workable longer than HMA allowing for a greater compaction window and easier handling of the mixture. The industry opinion is that the paving season can be extended utilizing WMA. This

means that WMA projects may be completed sooner (continuing paving operations in winter season without stop) to reduce the impact to traffic.

Question 3: What are the differences of QA/QC data between WMA and HMA projects, do you think? What is differently done about the QA/QC of WMA project?

Response 3: The differences of QA/QC between WMA and HMA projects are reported that QA/QC tests of WMA are dependent on the technology utilized. Some technologies, such as Foaming process, only remain active for specific time frames, therefore testing time frames must be established and testing details must be worked out prior to beginning paving operations in order to account for this. Other technologies are not impacted by time or heating-reheating so testing can be performed in the same manner as HMA.

Question 4: Are there some advantages or disadvantages of combining RAP and WMA, comparing with RAP and HMA (such as the amount of RAP used, any effects)?

Question 5: High contents of RAP can be incorporated into WMA due to the reduced aging of virgin asphalt. However, more than 20% RAP in a mix needs further binder testing to determine the PG of the blended binder. Have you ever done further tests to redetermine the PG of blended binder when the content of RAP is high? What tests did you do and how did the PG grade change?

Question 6: Variability of RAP and the degree of blending between virgin binder also affect the performance of mix, especially at lowered mixing temperature. RAP needs lower temperature to be mixed. For your experience, was the low temperature good for the blended WMA binder? How was the homogeneity of the blended binder with RAP and virgin WMA?

Response 4, 5 and 6: For the RAP used in WMA, it is believed that RAP content is dependent upon the technology utilized. Some technologies cannot handle high RAP contents as adequate mixing of the materials becomes an issue at the lower temperatures. Other technologies allow greater RAP contents with no issues with adequate mixing. The advantages of RAP used in WMA are the lower mixing temperatures do not age the virgin binder as much as traditional HMA and this could lead to a softer binder blend making the pavement less susceptible to low temperature cracking and allow higher percentages of RAP to be used. In addition, no issues with homogeneity of the blended RAP and virgin binder were found within 25% RAP. For RAP content more than 25%, AASHTO T319/ASTM D5404 will be performed, then test the recovered RAP binder and virgin binder according to AASHTO R29 and run the blending charts according to X1 of AASHTO M323 and X2.6 of AASHTO R35.

Question 7: The biggest concern about WMA is the amount of water left on the aggregate due to lower processing temperature. Does asphalt binder trap water as it coats the aggregate?

Question 8: Rutting resistance may be a concern for certain WMA technologies. The lower mixing and compaction temperatures for WMA cause the binder in WMA to age less than the binder in HMA, which indicates that WMA binder may be less stiff than HMA binder. Dose WMA have rutting problems after paving?

Response 7 and 8: For the concerns about rutting resistance and moisture damage of WMA projects and WMA laboratory tests, there are no issues about these reported so far.

Question 9: For the plant concern with WMA, low baghouse temperature of WMA can cause condensation. Have ever seen some problems with the baghouse?

Response 9: Low baghouse temperature of WMA can cause condensation. This was anticipated by the contractor and they would start out at a higher temperature to get their baghouse up to temperature and then drop the temperature to WMA temperatures, then at the end of the day they would increase the temperature to dry their baghouse before shutting down for the day.

Question 10: The WMA technologies used in New Mexico are mainly evotherm and foaming. How do you feel about these two technologies? Which technology do you think better (such as cost and performance)?

Response 10: The comparisons between evotherm additive and foaming process are reported that each one has its benefits. Foaming process is the most cost effective method while evotherm has a higher cost but also allows for lower temperatures than foaming. Both products have performed as expected so far so the difference in performance need further investigated.

Question 11: How are the pavements with WMA performing of your projects, any distress (cracking, deformation, deterioration and mat problems)?

Question 12: What do you think about WMA vs. HMA (serviceability and durability)?

Response 11 and 12: For the performance of WMA pavements, no issues have been observed so far. Since the WMA placed to date in NM has not been in place long enough to yield any definite performance data only opinions can be offered at this time. Those opinions should be based upon the experiences during placement and the knowledge of the outcomes of other agencies that have been producing WMA for longer periods of time. Based upon the uniformity and increased in-place density utilizing WMA one can expect that WMA pavement should perform better. Also, as the binders are not aged as much during production of WMA one can conclude that that is beneficial to the longevity of the pavement and aid in the prevention of premature cracking, however one needs to keep in mind the condition of the underlying pavement structure that the WMA was placed on, the WMA will not be a cure for issues with the underlying pavement structure.

Question 13: Any other concerns with WMA technologies (such as incomplete coating of aggregate, additional expense, and one more material/process to control)?

Response 13: One concern with WMA technologies applied in New Mexico is that WMA so far is that it has not been consistently put into projects, and this has slowed the ability of industry to maximize their operations for WMA and recoup the additional costs associated with WMA which is causing WMA to be slightly more expensive to produce and place.

Question 14: What improvements can be made to the NMDOT's specification for WMA?

Response 14: Suggestions proposed for the NMDOT's specification for WMA are as follows: Prescriptive temperatures (upper and lower) should not be used. The Producer should have the ability to adjust the temperatures based upon the WMA technology utilized, placement/production conditions and the binder grade used. Allow the option of WMA for every project so that producers can optimize their operations for WMA.

THIS PAGE LEFT BLANK INTENTIONALLY

EVALUATION OF WMA THROUGH FIELD SURVEY

After preliminary survey, field survey of the seven selected WMA projects was conducted by the Research Team, Industry Personnel, and Technical Panel members. The evaluation was conducted by mainly field visual inspection, and taking pictures. No coring and strength/stiffness testing were conducted.

EVOTHERM-25% RAP WMA PROJECT ON I-25

The WMA project on I-25 was constructed on the northbound road, whereas HMA project was constructed on the southbound road with the same pavement information as the WMA project.

This project is for roadway rehabilitation, which has 3.5 in. cold milling and 3 in. WMA inlay on the main traffic road. Superpave SP-III mix was used with performance grade PG 70-22. The shoulders of this project were fog sealed and old existing HMA pavement. About 0.5 in. standard open graded friction course (OGFC) was overlaid on the top of WMA pavement. This project is a non-QLA project. The whole project is in Albuquerque city with very high traffic volume with design ESALs 10.10 million. The material was mixed at 270 °F, placed at roughly 230 °F, and compacted down to temperatures of roughly 190 °F. The asphalt content is 4.7%, with 3.6% virgin asphalt binder.

General Pavement Condition after around 2 Years and 4 Months for the Project

Figure 8 shows the general pavement condition from the beginning milepost to the ending milepost of this project. It can be seen that the WMA pavement is still in good condition.



(a) Beginning Milepost



(b) Middle Milepost



(c) Ending Milepost

FIGURE 8 Pavement in Good Condition from the Beginning to the Ending Mileposts.

Problems/Distresses Found on the Project

Binder balls on the pavement, transverse cracking on shoulders and transverse reflection cracking on the edge of OGFC were found during the field trip as shown in Figure 9 and Figure 10.

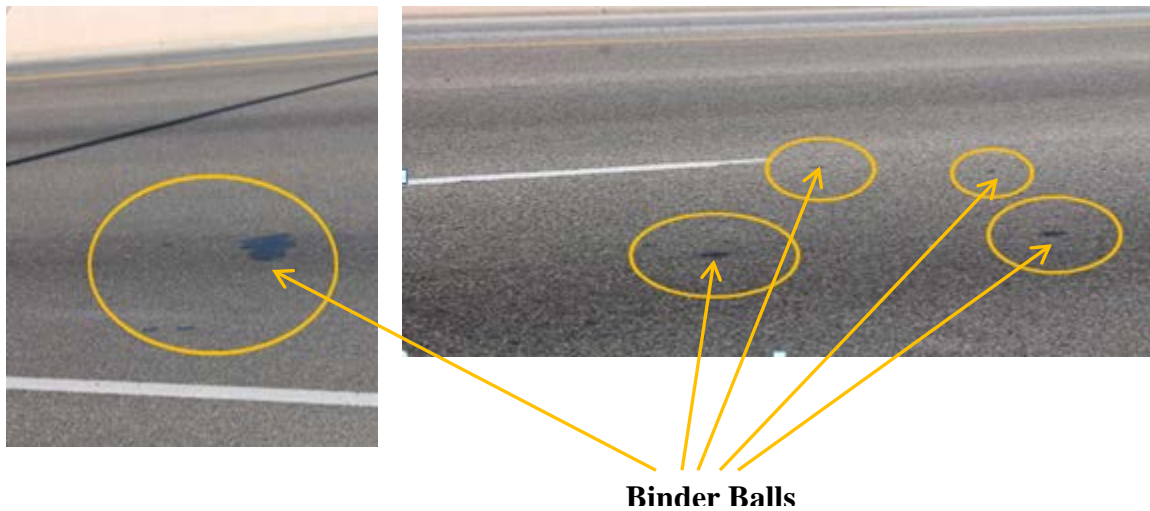

FIGURE 9 Binder Balls on the Pavement.



(a) Transverse Reflection Cracking on the Edge of OGFC



(b) Transverse Cracking on Shoulders

FIGURE 10 Transverse Cracking on the Edge of OGFC and Shoulders.

25% RAP HMA CONTROL PROJECT ON I-25

The HMA project is a roadway rehabilitation project on the southbound lanes of I-25, which was constructed with the northbound WMA project at the same time and with the same pavement information as the WMA project.

General Pavement Condition after around 2 Years and 4 Months for the Project

It can be seen from Figure 11 that the HMA control pavement is still in good condition.



FIGURE 11 General Pavement Condition of the HMA Control Project.

Problems/Distresses Found on the Project

Similar Binder balls, transverse cracking on shoulders were found during the field trip as shown in Figure 12 and Figure 13. In addition, the transverse cracking on shoulders starts extending to the edge of OGFC. Other problems found on the HMA project include that some longitudinal joints between asphalt mats started cracking and some pitting are found on the surface as shown in Figure 14.



FIGURE 12 Binder Balls.



FIGURE 13 Transverse Cracking on Shoulders.



FIGURE 14 Joint Cracking and Pitting.

I-25 WMA VS. I-25 HMA

The comparisons between WMA and HMA projects on I-25, constructed at the same time, indicate that the two pavements performance nearly the same. Both pavements are in good condition but contain some asphalt binder balls. Binder balls on the HMA pavement were found more than the WMA pavement. Pitting on the HMA pavement was found more than the WMA pavement. The shoulders for both projects were only treated by fog seal. Transverse cracking on the shoulders are observed throughout the projects with average severity 3 and extent 2. One transverse reflection cracking was found on the edge of OGFC on WMA due to the transverse cracking on the shoulder. For the HMA project, the transverse reflection cracking started to grow on the edge of OGFC. The oxidation of OGFC for both projects is almost the same, about 40%-60% based on visual observations. It means 40%-60% of the OGFC surface has turned gray from black surface.

EVOTHERM-0% RAP WMA PROJECT ON NM 264

It is also a rehabilitation project, instead of a reconstruction or new construction project. This project has 2.5 in. cold milling and 2.5 in. inlay. SP-III was used with PG 70-22. Standard OGFC was overlaid on the top of WMA pavement. This project is a QLA project. The whole project is in rural area with design ESALs 2.10 million. The material was mixed at 270 °F and laid down at 230 +/- 22 °F with 4.9% asphalt content.

General Pavement Condition after 2 Years and 7 Months

The general WMA pavement condition on NM 264 is good as shown in Figure 21.



FIGURE 15 General Pavement Condition of the WMA Project.

Problems/Distresses Found on the Project

Raveling and weathering were found on the OGFC top of the WMA project with severity 1 and extent 1, as shown in Figure 16. Figure 17 (a) shows the reflective cracking along the edge of

pavement after milling and inlay and Figure 17 (b) shows the joint cracking found on the surface of OGFC. In addition, longitudinal cracking were found on the sections with severity 1 and extent 1, as shown in Figure 18. Around the beginning milepost of this project, lots of bind balls were found that last hundred feet as shown in Figure 19.

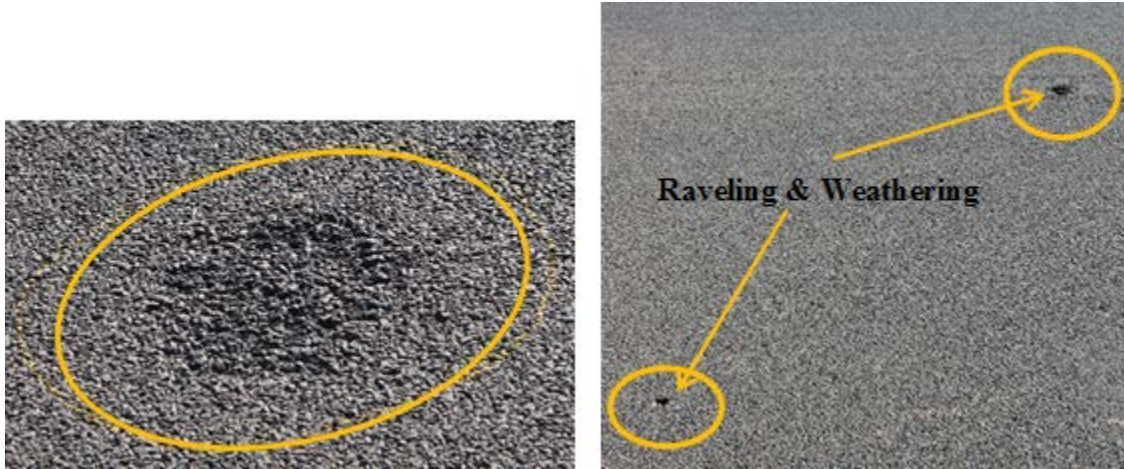

FIGURE 16 Raveling and Weathering.



(a) Reflective Cracking along the Edge of Pavement



(b) Normal Joint Cracking

FIGURE 17 Reflective Cracking and Joint Cracking.



FIGURE 18 Longitudinal Cracking.

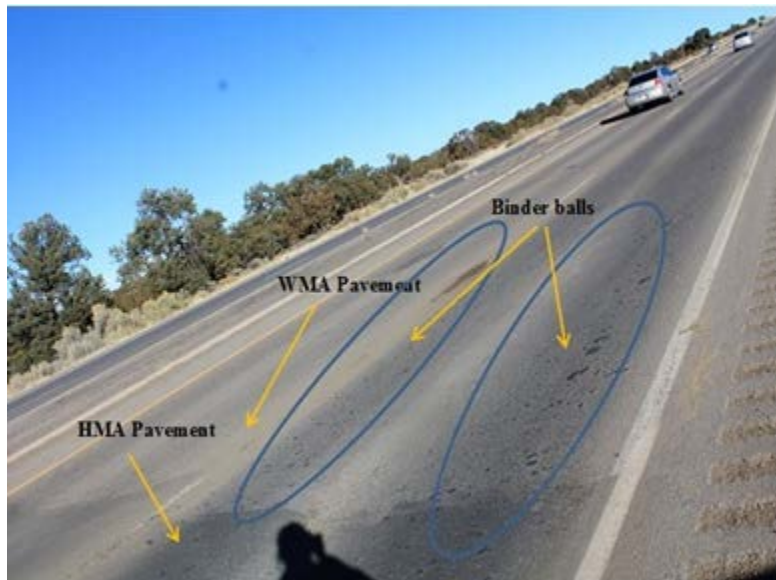

FIGURE 19 Binder Balls.

Summary

Comparing with the old HMA pavement on the same route, this WMA project shows better pavement condition. The OGFC on the top pavement has been oxidized 60%-70% throughout the project after two years and seven months. For this WMA project, raveling and weathering and longitudinal cracking were found on OGFC throughout the evaluation sections.

EVOTHERM-0% RAP WMA PROJECT ON NM 118

This is also rehabilitation project, which has 3 in. cold milling and 3 in. WMA inlay. SP-III was used with PG 70-22. No OGFC was overlaid on the top. This project is a QLA project. The whole project is in town with design ESALs 3.20 million. The material was mixed at 260 °F and laid down at 230 +/- 22 °F. The asphalt content is 4.3%.

General Pavement Condition after 1 Year and 7 Months

Figure 20 shows the general pavement condition of the WMA project. It can be seen that the pavement is still in good condition. Comparing with WMA pavement, it can be seen that the old HMA road appears minor to intermediate cracking and typical bleeding throughout its project (Figure 20).



FIGURE 20 General Pavement Condition of the WMA Project.

Problems/Distresses Found on the Project

As shown in Figure 21 and Figure 22, binder balls and segregation (near the edge of the pavement) were found throughout the project. Transverse cracking and longitudinal cracking were also found on the pavement with severity 1-2 and extent 1, as shown in Figure 23 and Figure 24. Figure 25 shows moisture related stripping on the pavement. Stripping was evident through the project due to moisture infiltration through the top surface of WMA without the protection of OGFC.



FIGURE 21 Binder Balls.



FIGURE 22 Segregation.

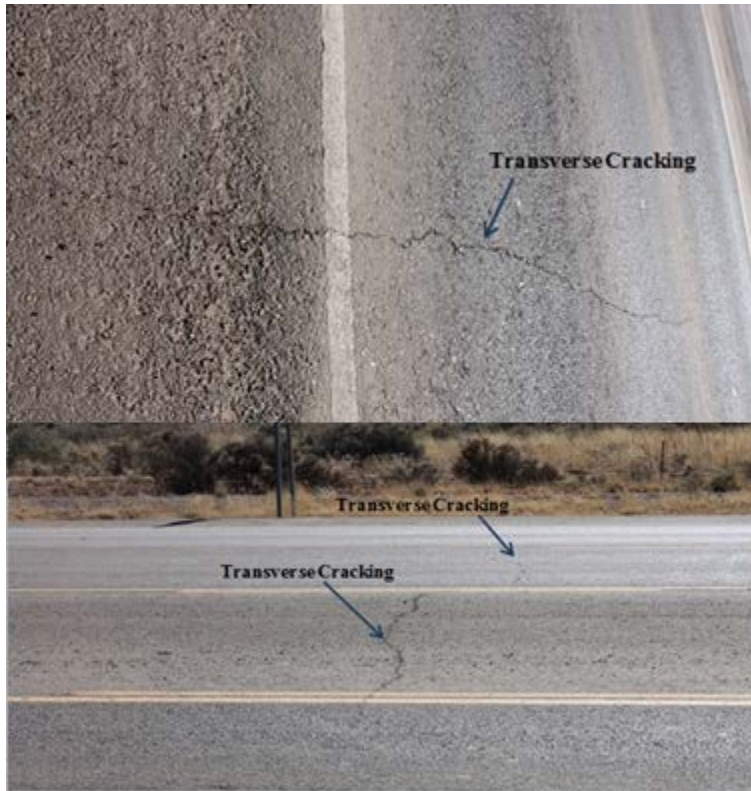

FIGURE 23 Transverse Cracking.



FIGURE 24 Longitudinal Cracking.



FIGURE 25 Moisture Stripping.

Summary

Compared to the old HMA pavement on the same route, the WMA project shows better pavement condition. The WMA pavement appears pink color throughout the project, which is due to the aggregate source used. Segregation and binder balls are shown throughout the whole project. They might be caused by the rollers up tight to the laydown operation on this project due to road side businesses. Several transverse and longitudinal cracking are found on the project. Apparently, they are reflective type, probably caused by the cracking underneath the WMA pavement.

EVOTHERM-0% RAP WMA PROJECT ON US 60

This is also a roadway rehabilitation project. This project has 3.5 in. cold milling and 3 in. WMA inlay. The Superpave SP-III was used with PG 76-28 with polymer. The shoulders of this project are the existing HMA pavement by fog seal. 0.5 in. Standard OGFC was overlaid on the top. This project is a non-QLA project. The whole project is in rural area with design ESALs 2.90 million. The material was mixed at 280 °F and laid down at 240 +/- 22 °F according to summary of mix design. The asphalt content is 5.8%.

Figure 26 shows the construction activities of this project. The range of laydown temperatures were around 240 °F to 272 °F, as shown in Figure 27. Figure 28 shows the road just after construction.



FIGURE 26 Road Constructions.



FIGURE 27 Laydown Temperatures.



FIGURE 28 Road after Construction.

General Pavement Condition after about 5 Months

Figure 29 shows that the general pavement condition of the WMA project is still very good.



FIGURE 29 Pavement in Good Condition from the Beginning to the Ending Mileposts

Problems/Distresses Found on the Project

Figure 30 shows white marks and cinders and binder balls found on the OGFC surface. Transverse cracking on the shoulder were found throughout the project with severity 3 and extent

3, as shown in Figure 31. A few longitudinal cracking on the shoulder were also found with severity 2 and extent 1, as shown in Figure 32.



FIGURE 30 White Marks and Cinders (Left) and Binder Balls (Right).



FIGURE 31 Transverse Cracking on Shoulders.



FIGURE 32 Longitudinal Cracking on Shoulders.

Summary

The overall OGFC pavement condition of traffic lanes of the WMA project on US 60 is very good without any distresses. Several binder balls were found on the section around milepost 70. The only problem of this project is the shoulders' distresses of existing HMA. Transverse cracking on the shoulders shows throughout this project. A few longitudinal cracks show on the shoulders around milepost 70.

FOAMED-25% RAP WMA PROJECT ON NM 48

This is also a roadway rehabilitation project. This project has 2 in. cold milling, tack coat, and 2 in. WMA inlay. SP-IV was used with PG 76-22. There is no OGFC on the top. This project is a QLA project. The whole project is in town with design ESALs 3.15 million. The material was mixed at 307 °F and laid down at 287 +/- 22 °F according to summary of mix design. The asphalt content is 5.4% with 4.2% virgin asphalt binder.

General Pavement Condition after about 6 Months

Figure 33 shows that the general pavement condition of the WMA project is still good. The first eighth of the project has fog seal applied at intersection of US 70 and NM 48 required by District 2. There are some tire tracks along road because of early opening of road to the traffic after fog seal.



FIGURE 33 Pavement in Good Condition from the Beginning to the Ending Mileposts.

Problems/Distresses Found on the Project

Figure 34 (left) shows binder balls were found throughout the project which may be due to high laydown temperature and tight rollers. Several segregations were also found on the pavement with severity 1 and extent 1, as shown in Figure 34 (right). Figure 35 (left) shows several pitting were found on the pavement with severity 1 and extent 1. Figure 35 (right) shows fines picked up lines on the pavement due to the roller picking up asphalt rich fines.



FIGURE 34 Binder Balls (Left) and Segregation (Right).



FIGURE 35 Pitting (Left) and Fines Picked Up (Right).

Summary

The overall pavement condition of the WMA project on NM 48 is good without any cracking, bleeding and rutting. The grey color of the pavement indicates high oxidation of the project only

after 6 months of construction. The cause of this phenomenon may be the high mixing temperature, which is 307 °F. In addition, binder balls are shown throughout the project. Several segregations and pitting were found on the road. Binder balls might be explained by the high laydown temperature of 287 °F combined with the need to keep the rollers tight because of the urban setting.

FOAMED-0% RAP WMA PROJECT ON I-40

This is a roadway rehabilitation project as well. The driving lanes had 6.5 in. of material milled out and inlayed with 3.0 in. of SP-III WMA then an additional 3.0 in. of WMA SP-III was overlaid across the full width of the road way after the passing lanes had 3.5 in. of material milled out. The driving lanes received 6.0 in. of SP-III WMA and the passing lanes received 3.0 in. of SP-III WMA. Binder PG grade 76-22 was used. A WMA OGFC was overlaid on the top with 0.5 in. This project is a QLA project. The whole project is in rural area with design ESALs 44.20 million. The material was mixed at 300 °F and laid down at 271 +/- 22 °F according to summary of mix design. The asphalt content of the mix is 4.2%. The material was placed beginning around the beginning of April and was completed around the middle of September.

Figure 36 shows the old HMA road conditions before WMA project. It can be seen that all kinds of cracking that exit on the road. The road is oxidized severely. Figure 37 shows the new WMA road condition just after construction. It can be seen that the new road is smooth and black.



FIGURE 36 Road Condition before WMA Project.



FIGURE 37 Road Condition after Construction.

General Pavement Condition after around 8 Months

As shown in Figure 38, the pavement condition is still in very good condition including the shoulders.



FIGURE 38 Pavement in very Good Condition from the Beginning to the Ending Mileposts.

Problems/Distresses Found on the Project

Figure 39 shows that few transverse cracking were found on the shoulder with severity 1 and extent 1, and the transverse cracking shown on the shoulder is caused by the sealed transverse

cracking on the shoulder of existing old HMA pavement. There are lots of transverse cracking along the existing HMA shoulder. Figure 40 shows one binder ball found on the WMA shoulder. Figure 41 shows the works done on the WMA shoulder around the end of the project with white spots and a dent. White color was found throughout the WMA shoulder which might be caused by the salt used to melt snow and the marks left by snow plow.

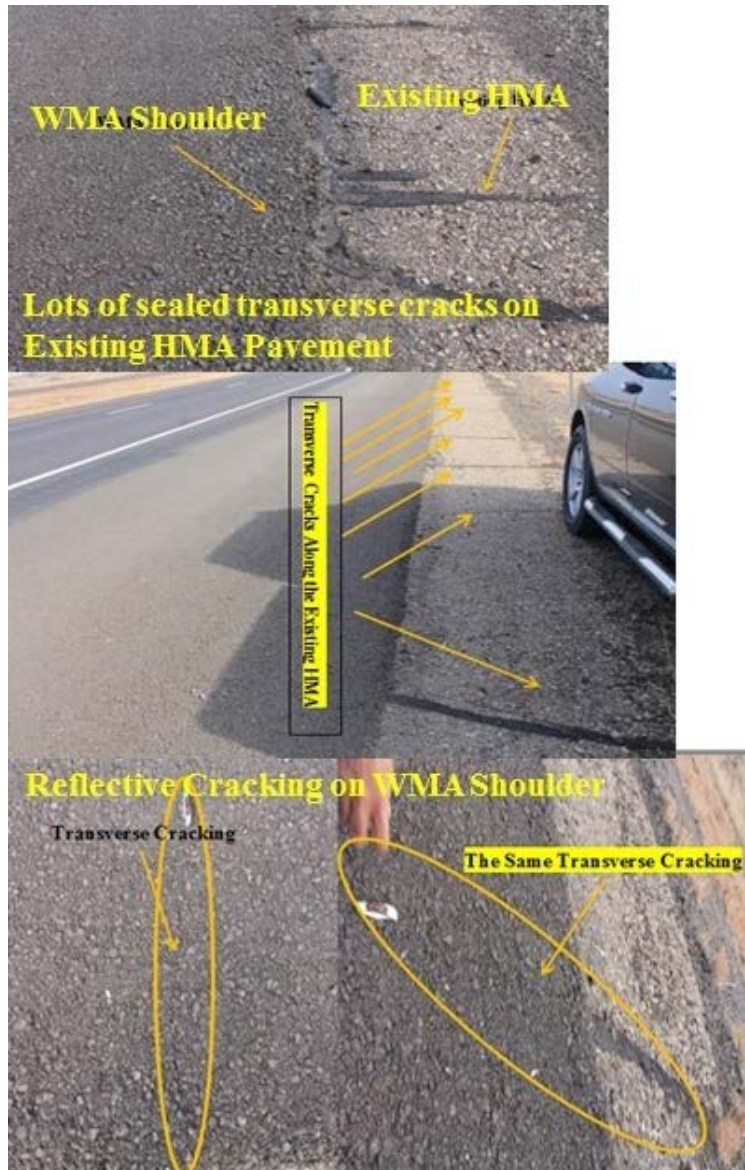

FIGURE 39 Transverse Cracking on the Existing HMA shoulders.



FIGURE 40 One Binder Ball Found on the WMA Shoulder.



(a) White Spots and Marks



(b) A Dent on the Shoulder

FIGURE 41 Works Done on the Shoulder around the End of Project.

Summary

The overall pavement condition of traffic lanes of the WMA project on I-40 is very good without any distresses and binder balls. The color of the OGFC pavement of the traffic lanes is black. There are a few of transverse cracks (reflective cracking) found on the edge of WMA shoulder due to the transverse cracking of the existing HMA underneath, around eastbound milepost 357. Around the same location, only one binder ball was found on the shoulder of this project. The white color found on the shoulder throughout the project might be caused by the salt used to melt snow and the marks left by snow plow. It should be noticed that the OGFC is made by WMA. Pavement oxidation of this project is not obvious.

FOAMED-0% RAP WMA PROJECT ON US 60

This is a roadway rehabilitation project. This project has 3 in. cold milling and 3 in. WMA inlay on the main traffic road. SP-III was used with PG 76-28. The shoulders of this project are the existing HMA pavement by fog seal. Standard OGFC was overlaid on the top of WMA pavement. This project is a QLA project. The whole project is in rural area with design ESALs 2.50 million. The material was mixed at 275 °F and laid down at 275 +/- 22 °F according to summary of mix design. The asphalt content is 5.7%.

General Pavement Condition after around 17 Months

Figure 42 shows that the pavement (OGFC) is still in good condition from the beginning to the ending mileposts of the WMA project.

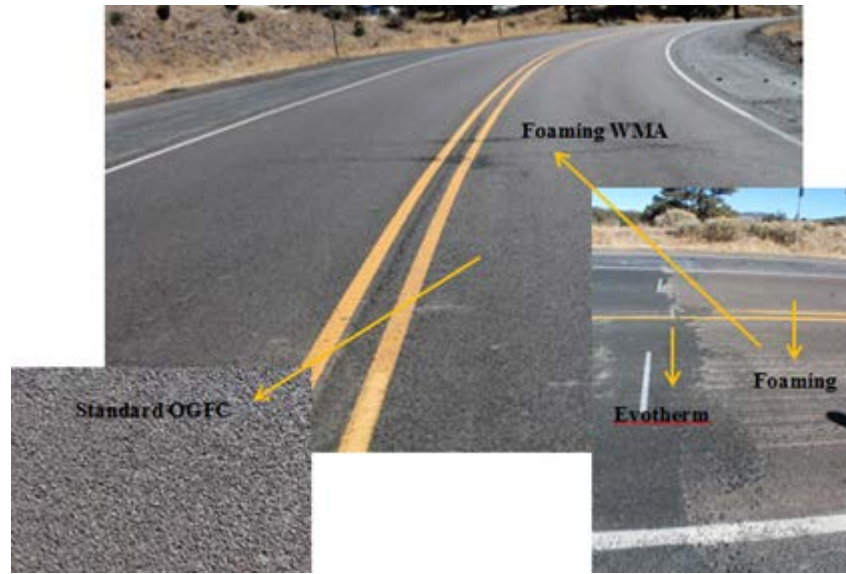

Beginning Milepost



FIGURE 42 Pavement in Good Condition from the Beginning to the Ending Mileposts.

Problems/Distresses Found on the Project

A lot of binder balls were observed on the section around milepost 73, and several pitting were found around the beginning and the end of the project, as shown in Figure 43.



(a) Binder Balls



(b) Pitting

FIGURE 43 Binder Balls and Pitting.

Some longitudinal cracks were found on both the edge of OGFC lane and the existing HMA shoulder with severity 1 and extent 1, as shown in Figure 44. Some longitudinal cracking on the edge of OGFC is due to the joint between new WMA pavement and old existing HMA pavement underneath, and some is due to the reflective cracking from the existing HMA pavement.



FIGURE 44 Longitudinal Cracking on the Edge of OCFC and the Existing HMA Shoulder.

Figure 45 shows transverse cracking found on both the OGFC surface and the existing HMA shoulder. Few transverse cracks were observed on the OGFC surface with severity 1 and extent 1. Some of the cracks were caused by the reflective transverse cracking of the existing HMA shoulder. The transverse cracking on the existing HMA shoulder were throughout the project with severity 2-3 and extent 2-3. The transverse cracking on the existing HMA shoulder might be partly due to the expansive clay under the shoulder, which is affected by freeze-thaw effects, as shown in Figure 46.

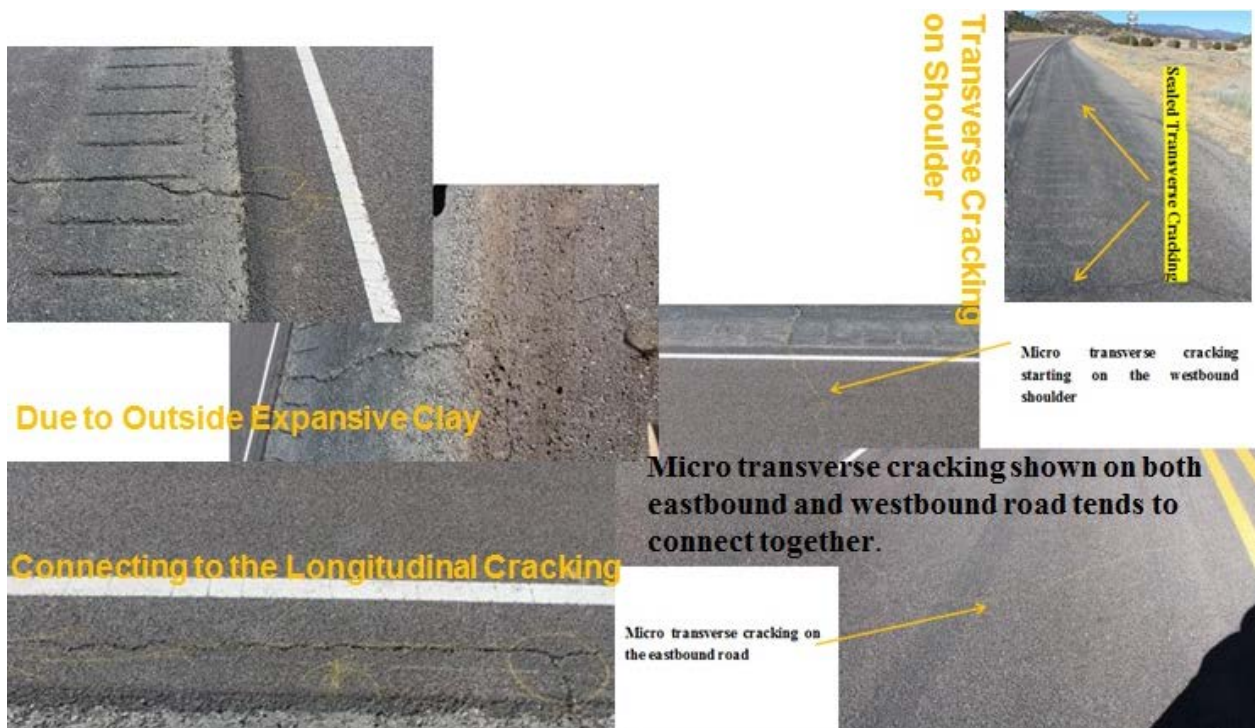

FIGURE 45 Transverse Cracking on the OCFC Surface and the Existing HMA Shoulder.



FIGURE 46 Expansive Clay Found on the Outside Westbound Shoulder.

Summary

The overall pavement condition of traffic lanes of the WMA project on US 60 is good. A Lot of binder balls were found on the section around milepost 73. Longitudinal cracking on the edge of OGFC were found all around the evaluation sections. Most of these cracks are caused by the underneath joint between new WMA pavement and old HMA pavement. Several transverse cracking were found along the project. The shoulder of this project was still the old existing HMA pavement with lots of transverse cracking. Several pitting were found at the beginning and end of the project.

CONCLUSIONS AND DISCUSSIONS

Field survey evaluation of the seven WMA projects and one HMA control project is summarized in Table 7. Overall, WMA performed well. Sections with OGFC performed better than non OGFC sections. All Pavements have cracks on the edge and shoulders, which might have reflected from old pavements. No clear distinction can be drawn between performances of evotherm versus foamed WMA. Some of issues are discussed in more detail.

TABLE 7 Summary of Field Survey.

Technology	WMA Project [RAP content (%)]	Old	OGFC	WMA Thickness (in.) [ESAL (million)]	Overall Condition	Pavement Traffic Lanes	Pavement edge	Pavement Shoulder
Evotherm	I-25 [25]	2 yrs 4 mons	Yes	3 [10.10]	Good	• Binder ball	• Transverse cracking	• Transverse cracking
	NM264 [0]	2 yrs 7 mons	Yes	2.5 [2.10]	Good	• Raveling • Weathering • Longitudinal cracking	• Reflective cracking	• No cracking
	NM118 [0]	1yr 7 mons	No	3 [3.20]	Good	• Binder ball • Transverse cracking • Longitudinal • Stripping	• Segregation	• None
	US60 [0]	5 mons	Yes	3 [2.90]	Good	• Binder ball	• None	• Transverse cracking • Longitudinal cracking
Foaming	NM48 [25]	6 mons	No	2 [3.15]	Good	• Binder ball • Segregation • Oxidation	• None	• None
	I-40 [0]	8 mons	Yes	6 for driving lanes, 3 for passing lanes [44.20]	Good	• Binder ball	• Transverse cracking	• Transverse cracking
	US60 [0]	1 yr 5 mons	Yes	3 [2.50]	Good	• Binder ball • Transverse cracking	• Longitudinal cracking	• None
Control	HMA I-25 [0]	2 yrs 4 mons	Yes	3 [10.10]	Good	• Binder ball	• Transverse cracking	• Transverse cracking

Common Issues

Binder Balls

All pavements show binder balls. It can be defined as the asphalt rich fines that appear as oily spots on the surface of the new mat. The most common reason to create binder balls is the result of the roller picking up asphalt rich fines from the WMA and depositing these fines on the surface of the mat randomly during compaction process. This occurs more frequently, when the steel wheel or pneumatic rollers are used at temperatures higher than optimum compaction temperature determined in the laboratory or when the rollers are cold at the beginning of the day. In addition, it should be noted that this also occurs to a lesser degree even when rolling occurs at optimum temperature, and is accelerated when rollers have issues with nozzles and pumps that result in intermittent water spray on the roller wheels/tires. The asphalt rich fines picked up can occur in various forms and patterns, and in the most severe cases, result in surface distresses that show as mild raveling, shelling or mild segregation.

Transverse and Longitudinal Cracking

The transverse and longitudinal cracking occurred on all the rehabilitation pavements, but they are not so severe, so that they can be considered as a failure of the pavement. Most of them are found on the edge of rehabilitation pavements. Transverse cracking was found on the existing HMA shoulders. Reflective cracking, which are caused by the cracking or joint underneath the new mat, were found in every pavement.

Oxidation

One difficulty to evaluate oxidation of WMA on all the projects is that, most projects have standard OGFC (HMA) on top except NM 48 (no OGFC), NM 118 (no OGFC) and I-40 (WMA OGFC). Another difficulty is caused by the different color of aggregate source used for each project. For instance, the pavements on NM 118 and US 60 show pink color because of the aggregates used were in red or rust color. The third difficulty to evaluate oxidation is the pavement with RAP incorporated, since the color of pavement with RAP is truly grayer than the pavement without RAP after construction. For all the projects, only the WMA project (25% RAP) on NM 48 shows an obviously oxidation due to high mixing and laydown temperatures.

WMA vs. HMA

The WMA project on the northbound lanes of I-25 has a HMA control project on the southbound lanes of I-25 constructed at the same time with identical pavement structure and similar mix design. The field evaluation shows that the WMA project performances the same as the HMA control project.

Evotherm vs. Foaming

Distresses and Oxidation

For the field survey, it is difficult to evaluate which technology (evotherm or foaming) is better, because most projects are covered by OGFC except the projects on NM 118 (evotherm) and NM

48 (foaming). The pavement condition of evotherm project on NM 118 shows similar distresses as the foaming project on NM 48. However, the oxidation of foaming pavement on NM 48 is much more severe than the evotherm pavement, and this might be due to the higher mixing temperature of the foaming project.

Mixing and Laydown Temperatures

Figure 47 illustrates the temperature comparisons between evotherm projects and foaming projects. The temperature comparisons between evotherm projects and foaming projects show that the mixing and laydown temperatures of the foaming projects are much higher than the evotherm project.

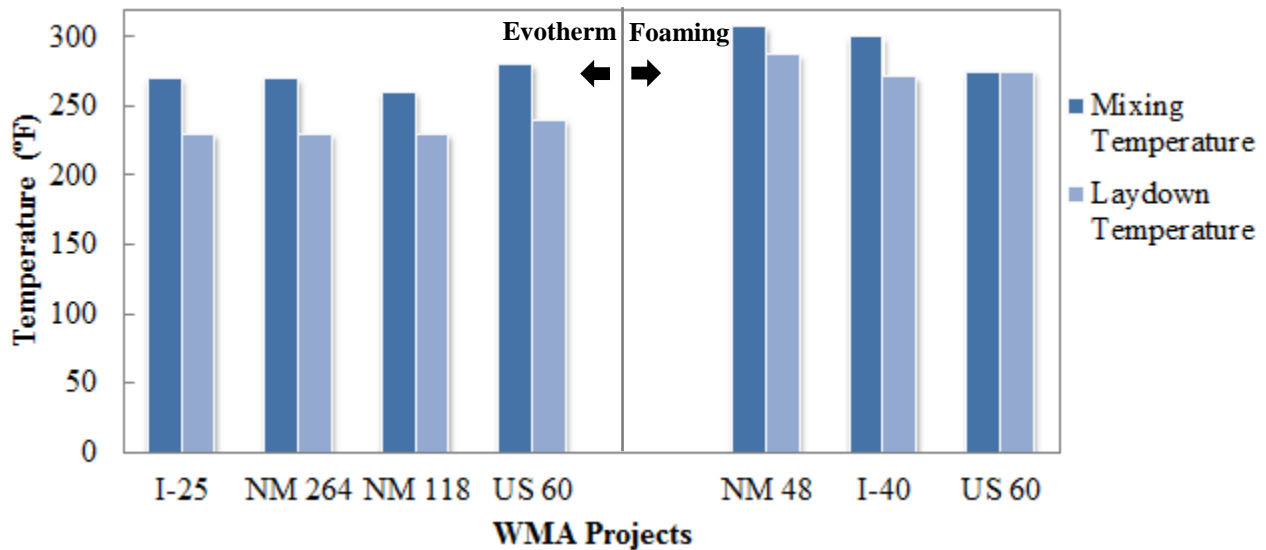

FIGURE 47 Comparisons of Mixing and Laydown Temperatures between Evotherm Projects and Foaming Projects.

Tensile Strength Ratio

TSR data is gathered from mix design information. TSR of foamed WMA is higher than that of the evotherm WMA, as shown in Figure 48. Overall, they are well above NMDOT’s minimum limit of 85% and comparable. As mentioned above, the mixing and laydown temperatures of all the foaming projects are too high, which might contribute to high TSR value. Further research is needed to examine the moisture susceptibility and stripping potential of the two WMA technologies.

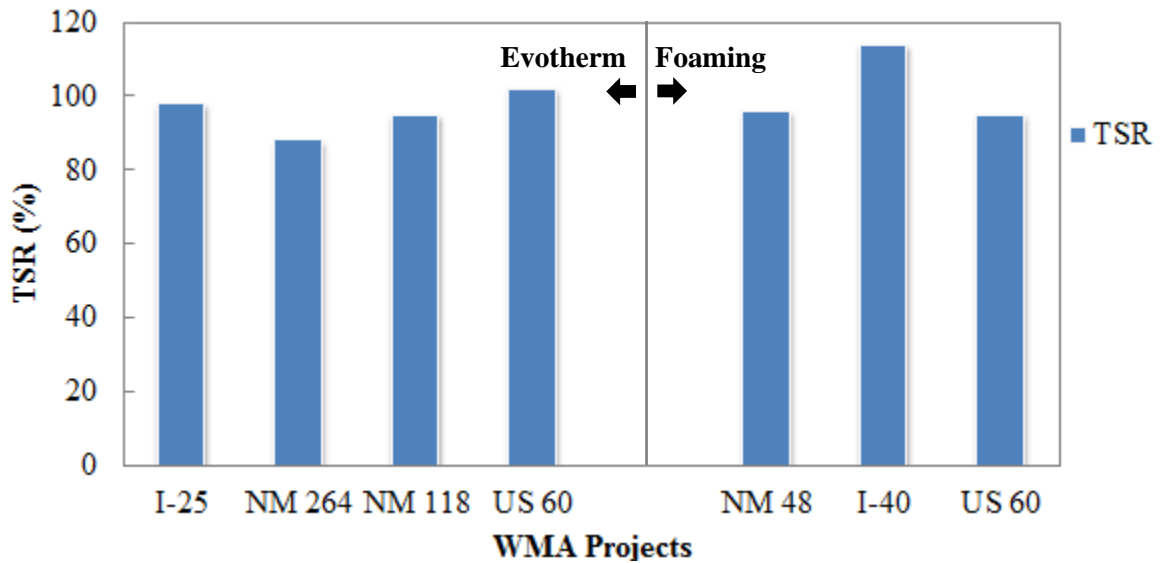

FIGURE 48 TSR Comparisons between Evotherm Projects and Foaming Projects.

Field Survey Limitations

- The field evaluation is not accurate to be defined as WMA evaluation, since most the WMA projects are covered by standard OFGC (the project on I-40 is WMA OGFC). The distresses and any problem on the new top mat only reveal the performance of OGFC except the projects on NM 48 and NM 118. Therefore, it is imperative to conduct further laboratory evaluation to decide which technology, evotherm additive or foaming process, is better.
- Some of the WMA projects used very high mixing (more than 300 °F [149 °C]) and laydown temperatures. Specifications need to be revised to further require the mixing and laydown temperature for each WMA technology. Recently, the new NMDOT specification for WMA project in New Mexico requires that the temperature of the WMA discharged from the mixer into the transport vehicle should not be greater than 275 °F (135 °C) or less than 215 °F (102 °C) unless written recommendations by the asphalt cement supplier, the WMA additive supplier and the mix design laboratory are provided (59).
- The implementation of WMA technologies in New Mexico started in 2011, so the service lengths of all the WMA pavements are too short to be compared with conventional HMA pavements.

Best WMA Technologies for New Mexico

According to the literature review above and the current WMA technologies implemented in New Mexico, the conclusions are made as follow:

- According to the evaluations of the seven WMA projects in New Mexico, Evotherm packages can reduce the production, molding, laydown, and compaction temperatures of WMA mixtures more than other foaming process technologies used in New Mexico.
- The three foaming process technologies (Double Barrel Green, AQUABlack WMA, and Warm Mix Asphalt System) require plant modifications, while no equipment changes at the plant or job site are required by evotherm technology.
- Warm Mix Asphalt system from Terex is suitable only for drum plants.
- Costs of the three foaming process technologies include equipment modification or installation, royalties per year, while the costs of Evotherm mainly include cost of material.

It is difficult to determine the best WMA technology now for New Mexico from the current implementation of WMA technologies in New Mexico. The reasons are from many considerations.

First, for the concern of cost, it is difficult to calculate the total cost of each technology. The main cost of foaming process technologies is the new system installation and royalties per year and there are no additional additives except water needed for producing mixture. For comparison, the main cost of Evotherm technology is the material and additive fee per ton. Since the implementation of WMA technologies in New Mexico started from 2011, which is a short period, and other potential savings from each technology cannot be evaluated at the initial stage, it is not possible to get an accurate economic benefit of each technology now.

Second, for the concern of short service life and different environmental conditions for constructions, it is not possible to conclude a best WMA technology in such a short time. WMA technologies are relative new in New Mexico as mentioned above. Long-term evaluations are needed for each technology.

THIS PAGE LEFT BLANK INTENTIONALLY

EVALUATION OF WMA USING PAVEMENT MANGEMENT DATA

WMA condition data collected by NMDOT's Pavement Management Division were gathered for six WMA projects one HMA control project in Table 6 and Figure 7. Evotherm WMA project on US 60 with number 6100451 were excluded for this evaluation because the project was not completely finished when the Pavement Management Division collected the field condition data.

METHODOLOGY

Two measures: roughness and distresses data are combined into a pavement condition index called Pavement Serviceability Index (PSI). All the data came from automatic survey vehicles, which collected data at highway speeds. The evaluation was in accordance with the criteria established by the NMDOT's Pavement Management System (PMS) (60).

Most of WMA projects selected in this study, with the exception of NM 118, and NM 48, have OGFC surfaces that cover the WMA surface. All of the OGFC's surfaces placed, were conventional HMA, not WMA. Therefore evaluating the actual WMA surface is limited in most cases, as most of the distresses were measured on the OGFC surface. Another limitation is that all of these projects were milled and filled, and/or overlay construction. As such, defects such as longitudinal and transverse cracking might have reflected through to some degree within a year, plus or minus 6 months, depending on the severity of the existing cracks. Therefore, exact causes of failures or cracks are not only reated to WMA, but also the HMA layers below. Yet, this study attempts to answer some of the questions: (i) Is evotherm performing better than foaming technology? (ii) Is there a sign of premature failure, such as rutting with WMA technology? (iii) Are WMA pavements performing as expected or as good as HMA pavements?

Pavement roughness and distress data were collected along each entire WMA project and averaged for every 0.1-mile (161-meters) long roadway sections. Data in both positive and negative directions were collected, represented by P and M (not N, which may confuse with North direction), respectively. For roadways that run east-west, the positive direction is the east-bound lane and the negative direction is the west-bound lane. For roadways that run north-south, the positive direction is the north-bound lane and the negative direction is the south-bound lane.

Pavement Roughness

Pavement roughness is measured in terms of the International Roughness Index (IRI) in units of inches per mile. The roughness measure can range from as low as 10 to nearly 1000. The Federal Highway Administration (FHWA)'s IRI criteria requires that a good IRI value should be less than 95 in./mi (1.5 m/km) and an acceptable IRI value should be less than 170 in./mi (2.7 m/km) (61).

Pavement Distresses

There are eight major distresses that the majority of state DOTs including NMDOT uses to rate flexible pavements. These distresses are raveling and weathering, bleeding, longitudinal

cracking, transverse cracking, fatigue/alligator cracking, edging cracking, patching, and rutting. In this study, all the eight distresses are reported in linear feet with exception of rut depth which is in inches and fatigue cracking which is in square feet. These distresses are then translated into corresponding severity and extent, ranging from 1 to 3, respectively. Distresses, except rutting, the severity and extent of each distress are measured according to the NMDOT's Distress Evaluation Criteria shown in Table 7 (60).

It can be seen from Table 7 that longitudinal cracking is defined as cracks outside the wheel path. Longitudinal cracking in the wheel path is considered as fatigue cracking, since longitudinal cracks within the wheel path indicate early-stage fatigue cracking.

TABLE 7 NMDOT's Distress Evaluation Chart for Flexible Pavements (60).

Distress	Severity	Extent/Notes
Raveling & Weathering: The wearing away of the pavement surface, due to dislodged aggregate particles and loss of asphalt binder.	(1) Low: Aggregate or binder has started to wear away (2) Medium: Surface texture is rough. Some dislodged aggregate can be found on the shoulder. (3) High: Aggregate and/or binder has worn away, and surface texture is severely rough and pitted.	Report the extent of the most prevalent severity found throughout the specimen section. Extent is assumed to be the entire section.
Bleeding: A film of bituminous material on the pavement surface, from the asphalt concrete mix and not from the vehicles or external sources.	(1) Low: Film is evident, but aggregate can still be seen. Spotty. (2) Medium: Film is clearly seen, covers most of the aggregate and is a little sticky. (3) High: Film is predominant, very sticky, and material is thick enough to shove.	Report the extent of each severity found within the specimen section. (1) Low: 1% to 30% (2) Med: 31% to 60% (3) High: 61% or more.
Transverse Cracks: Half-width lane to full-width lane transverse cracks (6ft or longer cracks). Disregard cracks shorter than 6 ft (Highway Performance Monitoring System [HPMS] recommendation)	(1) Low: Unsealed, mean width of less than 1/4-inch. OR sealed with sealant in good condition, any width. (2) Medium: Any crack with mean width greater 1/4-inch and less than 3/4 inch. May have adjacent Low severity random cracks, some spalling. (3) High: Any crack wider than 3/4 inch, may have adjacent moderate to high random cracking.	Report the number of cracks of EACH severity within specimen section. Extent 1 = 0-8 cracks Extent 2 = 9-16 cracks Extent 3 = 17+ cracks
Fatigue/Alligator Cracks: Cells are less than 1 ft ² in size. Longitudinal cracks in the wheel path are rated as Low severity alligator cracking. Severities 2 and 3 must have at least 3 cells.	(1) Low: Hairline, disconnected cracks, 1/8-inch wide or less, less than 3 cells. No spalls. AND/OR a longitudinal crack, any severity, in the wheel path. (2) Medium: Fully developed cracks greater than 1/8-inch wide. Three or more cells. Lightly spalled. (3) High: Severely spalled, cells rock, and may pump.	Report the percent area of EACH severity present. Round up to the next 5% increment.
Edge Cracks: Cracks that lie within 1 foot on either side of the white edge line. Does NOT apply in roads with curb and gutter installations.	(1) Low: Less than 1/4-inch wide. No spalls. (2) Med: Greater than 1/4-inch wide. Some spalling may be present, but pavement is still intact. (3) High: Severely spalled. Pieces of pavement have broken off the edge of the roadway.	Report the extent of the MOST PREVALENT severity found throughout the specimen section. (1) Low: 1% to 30% (2) Med: 31% to 60% (3) High: 61% or more.

TABLE 7 (continued).

Distress	Severity	Extent/Notes
Longitudinal Cracks: ANY longitudinal crack NOT in the wheel path, but NOT within 1 foot of the inside pavement edge line. If curb and gutter, any cracking outside the wheel path is rated.	(1) Low: Unsealed, mean width of less than ¼-inch. OR sealed with sealant in good condition, any width. (2) Medium: Any crack wider than ¼-inch and less than ¾ inch. May have adjacent Low severity random cracks and some spalling. (3) High: Any crack wider than ¾ inch, may have adjacent moderate to high random cracking and spalling.	Report the extent of the MOST PREVALENT severity found throughout the specimen section. (1) Low: 1% to 30% (2) Medium: 31% to 60%. (3) High: 61% or more
Patching: Any new pavement placed into the pavement section. Extent is rated as percent of the test section affected, usually describes the largest patch.	(1) Low: Patch is in good condition. (2) Medium: Somewhat deteriorated, has Low to Medium severities of any distress present. (3) High: Needs replacement. High Severity of any distress, gaps are present between the pavement and the patch.	Report the extent of the MOST PREVALENT severity found (1) Low: 1% to 30% (2) Med: 31% to 60% (3) High: 61% or more

The rutting distress is measured by the average rut depth. The extent is always 3 since the measure applied to the entire rated section. The severity is based on the rut depth in Table 8 according to Pavement ME Design Guide's recommended values. From Table 8, Interstate and NM and US Roads refer to highway functional classes according to FHWA criteria (62). Interstate column are used the evaluation of the WMA projects on interstates such as I-25 and I-40. NM and US Roads column are used for the evaluation of local New Mexico or state roads.

TABLE 8 Rutting Evaluation Criteria.

Rut Depth	Severity	
Interstate (high traffic volume)	NM and US Roads (low traffic volume)	
0 – 0.125 in.	0 – 0.125 in.	0
0.125 in. – 0.25 in.	0.125 in. – 0.25 in.	1
0.25 in. – 0.50 in.	0.25 in. – 0.50 in.	2
>0.50 in.	>0.65 in.	3

Pavement Serviceability Index (PSI)

PSI ranges from 0 (very poor condition) to 5 (very good condition). PSI is calculated using distress rate and IRI. The empirical expressions for PSI calculation are given below (60):

$$PSI = 0.041666 X, \quad \text{if } X \leq 60 \quad (1)$$

or

$$PSI = [0.0625(X - 60)] + 2.4999, \quad \text{if } X > 60 \quad (2)$$

where X is given by

$$X = 100 - [(0.6(IRI - 25) + (0.4DR))/2.9] \quad (3)$$

where IRI is International Roughness Index, and DR is the Distress Rate defined as

$$DR = \sum_{i=1}^n [(Severity Rating_i)(Extent Factor_i)(Weight Factor_i)] = \sum_{i=1}^n (DR_i) \quad (4)$$

in which i denotes one of the eight types of distresses of pavements $n = 8$, and DR_i is the component of the distress rate (DR) value corresponding to the distress type i for a given pavement section.

The extent factors and weight factors for the eight distresses currently used by the NMDOT for the calculation of distress rate and PSI are given in Table 9.

TABLE 9 Factors for Extent Ratings and Weight Factors for Flexible Pavement Distresses.

Distress Type	Weight Factor	Extent Level	Extent Rating	Extent Factor
Raveling and Weathering	3	Low	1	0.3
		Medium	2	0.6
		High	3	1.0
Bleeding	2	Low	1	0.3
		Medium	2	0.6
		High	3	1.0
Rutting and Shoving	14	Low	1	0.5
		Medium	2	0.8
		High	3	1.0
Longitudinal Cracking	9	Low	1	0.7
		Medium	2	0.9
		High	3	1.0
Transverse Cracking	12	Low	1	0.7
		Medium	2	0.9
		High	3	1.0
Alligator Cracking	25	Low	1	0.7
		Medium	2	0.9
		High	3	1.0
Edge Cracking	3	Low	1	0.5
		Medium	2	0.8
		High	3	1.0
Patching	2	Low	1	0.3
		Medium	2	0.6
		High	3	1.0

Using the formulas and Table 9 values shown above, PSI values are calculated for six WMA projects. Depending on the calculated PSI value limits shown in Table 10, WMA are categorized as good, poor, or deficient etc.

Table 10 shows the NMDOT's ranking of pavement condition based on PSI values.

TABLE 10 NMDOT’s Ranking of Pavement Condition Based on PSI Values.

New Mexico PSI Range	Pavement Condition		
	Condition Ranking	Interstate Highways	Non-Interstate Highways
$4.00 \leq \text{PSI} \leq 5.00$	Very Good	Non-deficient	Non-deficient
$3.00 \leq \text{PSI} < 4.00$	Good	Non-deficient	Non-deficient
$2.50 \leq \text{PSI} < 3.00$	Fair	Deficient	Non-deficient
$1.00 \leq \text{PSI} < 2.50$	Poor	Deficient	Deficient
$0.00 \leq \text{PSI} < 1.00$	Very Poor	Deficient	Deficient

WMA CONDITION DATA ANALYSIS

Table 11 shows the field survey date and the service length of each selected WMA project. It can be seen that Evotherm pavements are in service longer than the Foaming pavements, most of which have been opened to the traffic for less than one year.

TABLE 11 Evaluation Dates and Service Lengths of Six WMA Projects.

Evotherm	Construct ion Date	Evaluation Date	Service Length	Foaming	Construct ion Date	Evaluation Date	Service Length
I 25	Aug. 2011	Sep. 2013	2.08 years	NM 48	Jun. 2013	Sep. 2013	0.25 year
NM 264	May 2011	Nov. 2013	2.5 years	I 40	Apr. 2013	Jan. 2014	0.75 year
NM 118	May 2012	Nov. 2013	1.5 years	US 60	Jul. 2012	Sep. 2013	1.17 years

The IRI value, distresses, and PSI value for each of the WMA project are discussed below:

Pavement Roughness (IRI)

Figure 8 shows the box plot of the IRI values for all WMA projects. The box plot depicts a group of numerical data through their quartiles. The top and low whiskers represent maximum and minimum values, respectively. The bottom and top of the box are the first and third quartiles, and the band inside the box is the median. The median to the top of the box are shown in blue color and the bottom to the median of the box are shown in gray color. The green and orange dot lines are used for reference with value 95 (good pavements) and 170 (acceptable pavements), respectively. The IRI value below the green dot line indicates good pavement roughness, and the value below the orange dot line indicates acceptable pavement roughness.

From Figure 49, overall all six sections exhibit acceptable IRI values. It can be seen that the average IRI of all the three evotherm projects is slightly higher than the average IRI of the three foaming WMA projects. This might due to longer service time of the evotherm projects than the foaming projects. However, the foaming project on NM 48 has the highest IRI value among all the WMA projects, and its IRI values are above the acceptable IRI limit of 170 in the negative direction (NM 48 M).

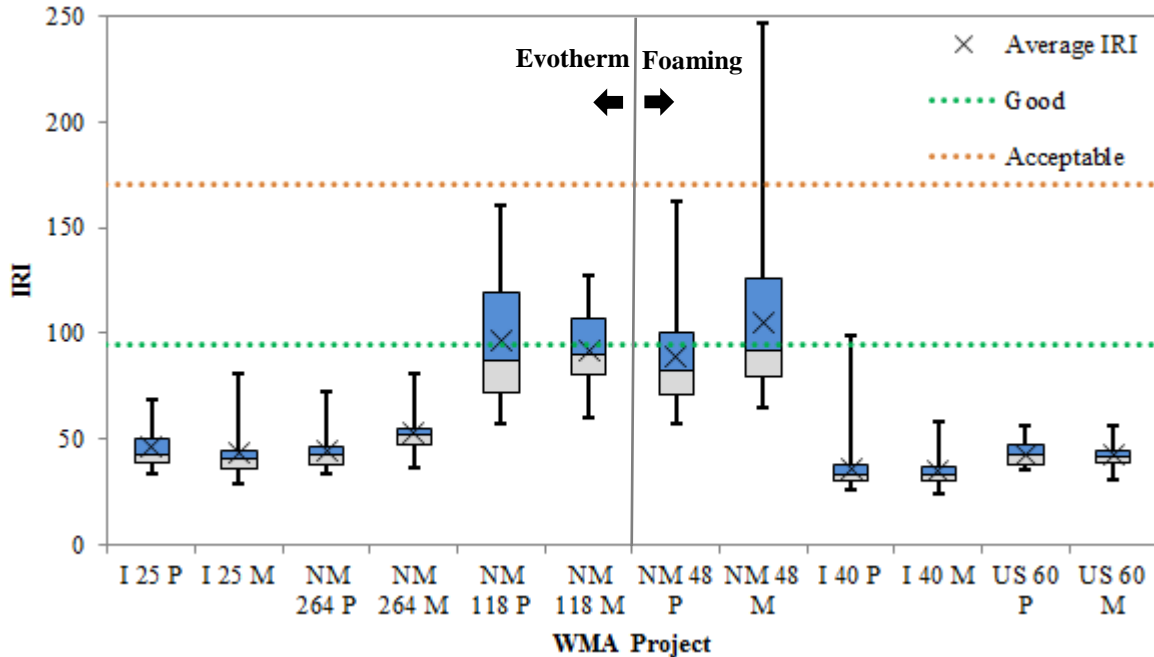

FIGURE 49 Box Plot of IRI for Each WMA Project.

Figure 49 also exhibits that one evotherm project (NM 118) and two foaming projects (NM 48 and I 40) have IRI values higher than the good category limiting IRI value of 95.

For WMA pavements (I 25 P and NM 48) with RAP, it can be seen from Figure 49 that the IRI values of evotherm-RAP pavement (I 25 P) are low, while the IRI values of foaming-RAP pavement (NM 48) are the highest among all the projects. As both of these WMA projects contain 25% RAP, it is logical to say that evotherm technology produces better roadway IRI than the foaming technology.

To compare the WMA project on I 25 P with the HMA control project on I 25 M, it can be seen from Figure 8 that the average IRI of the WMA pavement is slightly higher (means worse) than the HMA pavement, while the maximum IRI value of the WMA pavement is the lower than the maximum IRI of HMA. In general, the difference in IRI between the WMA and the HMA pavements is too small to draw a definitive conclusion.

Raveling and Weathering

The distress rate of raveling and wreathing ranges from 0 to 9 according to Eq. (4) and Table 9 values. All the WMA projects have shown to have the same raveling and weathering distress rate, which is 3, along with severity 1 and extent 3. This indicates aggregate or binder has started to wear away in early life of these WMA pavements.

Bleeding

The distress rate of bleeding ranges from 0 to 6 to Eq. (4) and Table 9 values. The bleeding distress rates of all the six WMA projects are calculated to be 0, with an exception to the

evotherm project on NM 118 P. The distress rate of bleeding this evotherm pavement is found to be 0.6, with severity 1 and extent 1. This bleeding was found only towards the end of the project on NM 118 P, which might have been caused by a silly construction mistake, however it could not be verified in this study.

Transverse Cracking

The distress rate of transverse cracking can be calculated within the ranges from 0 to 36 according to Eq. (4) and Table 9 values. Figure 50 shows the box plot of the distress rate of transverse cracking of each WMA project. It can be seen that the evotherm pavements have higher transverse cracking distress rate compared to the foaming pavements. It might be again due to longer service time of evotherm projects. The highest distress rate of transverse cracking is 25.2, with severity 3 and extent 1.

For WMA pavements (I 25 P and NM 48) with RAP, it can be seen from Figure 50 that transverse cracking rate is the highest in the WMA-RAP pavements. Moreover, the average distress rate of transverse cracking on evotherm-RAP pavement (I 25 P) is slightly higher than the foaming-RAP pavement (NM 48). Therefore, it can be concluded that RAP in evotherm WMA technology suffers from transverse cracking. It is well known that use of RAP always produce stiff asphalt mixture. The use of evotherm has probably made the mix even stiffer, as there exists a speculation that evotherm works like DuPont's Elvaloy® type polymer that reacts chemically with the asphalt binder.

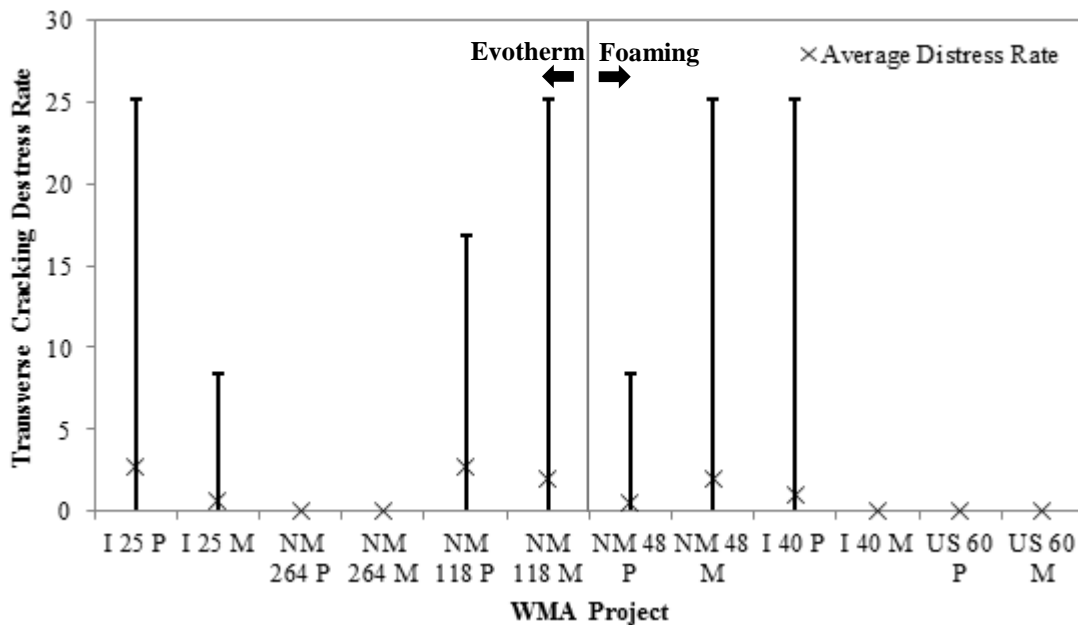

FIGURE 50 Box Plot of Distress Rate of Transverse Cracking for Each WMA Project.

When comparing the transverse cracking of the WMA project on I 25 P with that of the HMA control project on I 25 M, it is obvious from Figure 50 that the distress rate of transverse cracking of the WMA pavement is higher than the HMA pavement.

Fatigue Cracking

The distress rate of fatigue cracking can be calculated to be within the range from 0 to 75 according to Eq. (4) and Table 9 values. Figure 51 shows the box plot of the distress rate of fatigue cracking for each WMA project. It can be seen that the average fatigue cracking distress rate of all the foaming pavements, with shorter service length, is higher than the evotherm pavements. The highest value of distress rate is found on the positive direction of the evotherm pavement on NM 264, with severity 3 and extent 1. However, the fatigue cracking differences between WMA-RAP (NM 48, I-25) pavements and WMA pavements are small.

Again, when comparing the fatigue performances of the WMA project on I 25 P with the HMA control project on I 25 M, it can be seen from Figure 51 that the distress rate of fatigue cracking of the WMA pavement is higher than the HMA pavement.

Base on this study, it can be concluded that fatigue life of HMA and evotherm WMA pavements are slightly longer than the fatigue life of foamed WMA pavements.

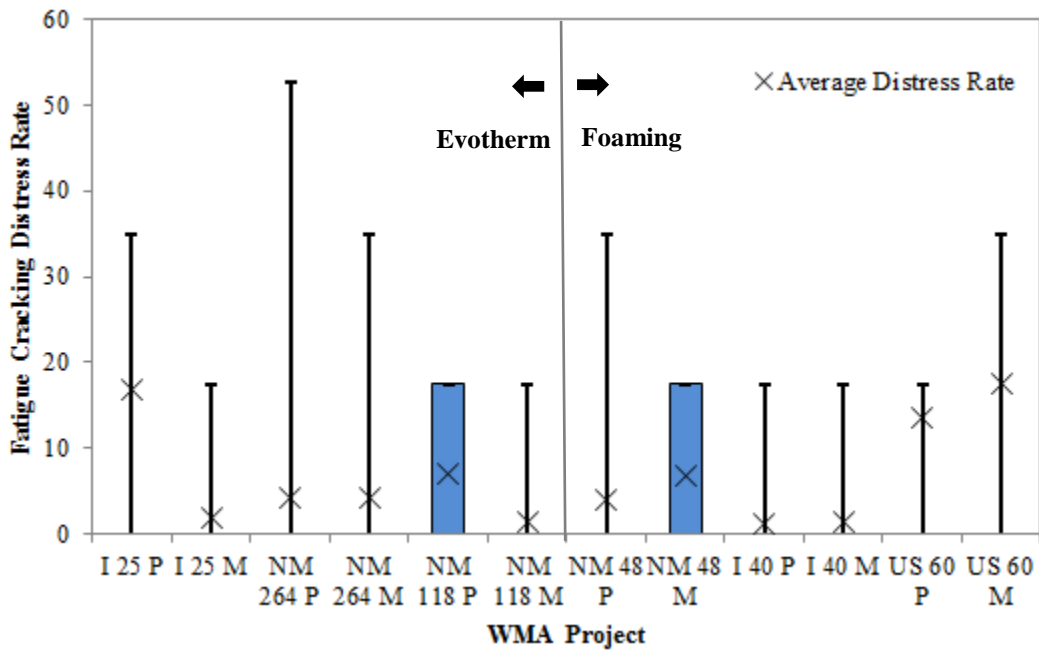

FIGURE 51 Box Plot of Distress Rate of Fatigue Cracking for Each WMA Project.

Edge Cracking

The distress rate of edge cracking can be calculated according to Eq. (4) and Table 9 values and found to be within the range from 0 to 9. All the WMA pavements have no edge cracking as expectation except Foaming project on I 40 P. The edge cracking on I 40 P was found towards the end of the project with severity 1 and extent 1. This section of I-40 is known to be located in an area (near Tucumcari, NM) which is subjected to severe weather including a large number of freeze-thaw cycles. Indeed, a field investigation carried out by a research team that includes personnel from NMDOT, evotherm supplier, and the authors of this paper discovered that this

section of the pavement was rehabilitated only because of edge cracking, however surprisingly the shoulder was not paved. As a result, existing edge cracks from the shoulder of the old pavement were found to be progressing towards the new WMA pavement lanes. Therefore, the edge cracking of this pavement among the six WMA pavements can be considered as an outlier.

Longitudinal Cracking

The distress rate of longitudinal cracking can be calculated to be within the ranges from 0 to 27 according to Eq. (4) and Table 9 values. Figure 52 shows the box plot of the distress rate of longitudinal cracking for each WMA project. It can be seen that the average distress rate of longitudinal cracking of all the evotherm projects, with longer service length, is higher than the Foaming projects. However, the highest value of distress rate is found on the foaming pavement on NM 48 P, with severity 3 and extent 1. It can be noted that though evotherm WMA pavements are 1-2 year older than the foamed WMA, both type of pavements can be considered relatively new as their service life is below 3 years. Therefore, in a relative term, one can say that evotherm technology in New Mexico is worse than foaming when considering longitudinal cracking.

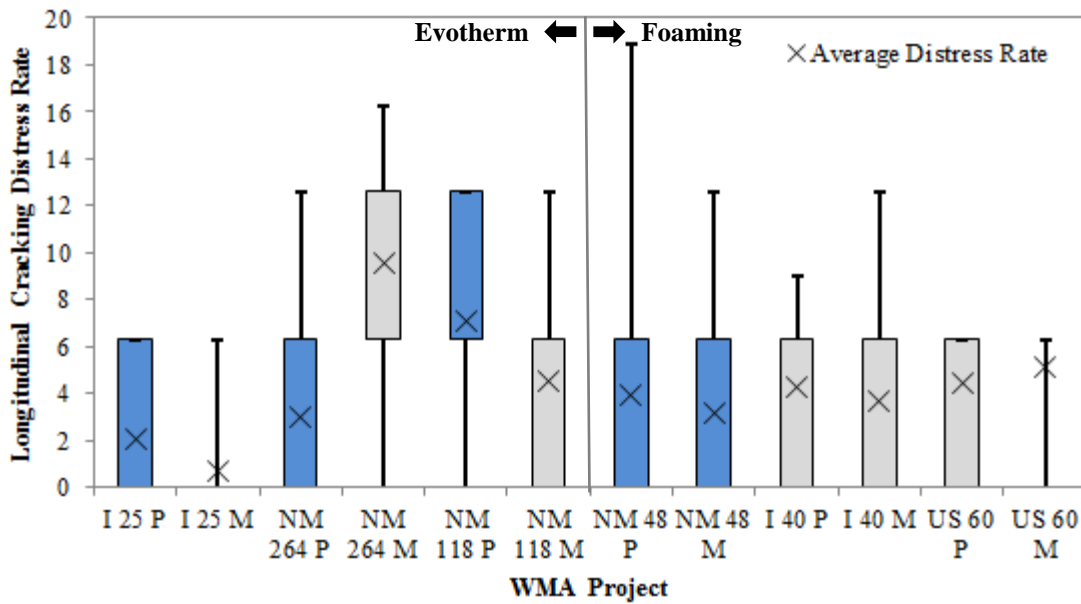

FIGURE 52 Box Plot of Distress Rate of Longitudinal Cracking for Each WMA Project.

For WMA pavements (I 25 P and NM 48) with RAP, it can be seen from Figure 52 that longitudinal cracks found on the WMA pavements with RAP are less than the WMA pavements without RAP. Moreover, the average distress rate based on longitudinal cracking of foamed-RAP WMA pavement (NM 48) is similar to that of the evotherm-RAP WMA pavement (I 25 P).

When comparing the WMA project on I 25 P with the HMA control project on I 25 M, it is shown from Figure 52 that longitudinal cracking of the WMA pavement is higher than the HMA pavement.

Patching

The distress rate of patching can be shown within the ranges from 0 to 6. The distress rates of patching on the six WMA projects were found to be 0 with the exception of the evotherm project on NM 264 M. The distress rate of patching of this evotherm pavement is found to be 1, with severity 1 and extent 1.

Rutting

Figure 53 shows the box plot of the rut depth of all WMA pavements. The green and orange dot lines are used to refer to the depth range of severity 1 from 0.125 in. (green dot lines) to 0.25 in. (orange dot lines) according to Table 3. Overall average rut depth of the evotherm projects is higher than the foaming projects. All the evotherm projects have rut depth of severity 1.

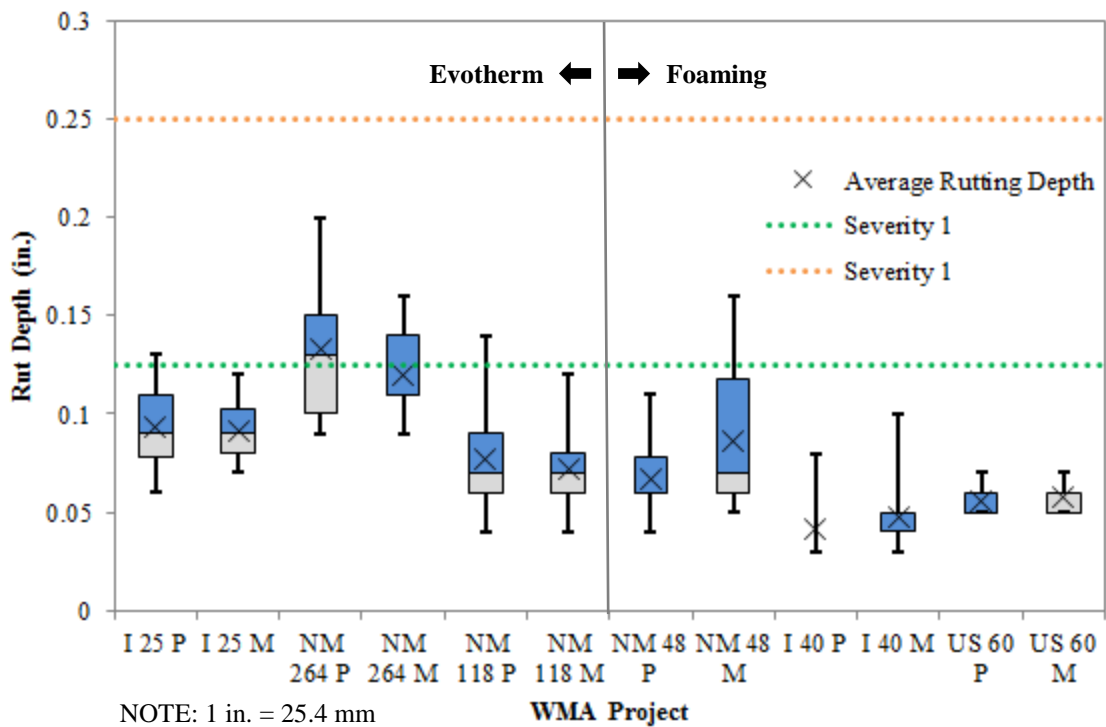

FIGURE 53 Box Plot of Rut Depth for Each WMA Project.

For WMA pavements (I 25 P and NM 48) with RAP, it can be seen from Figure 53 that the rut depth of evotherm-RAP pavement (I 25 P) is similar to that of the other evotherm projects. However, the rut depth of foaming-RAP pavement (NM 48) is slightly higher than that of the other foaming projects with a severity value of 1 for all foaming projects. This is very unusual because RAP is usually expected to reduce rutting. Therefore it can be speculated that WMA pavements suffer more rutting even if they use RAP in it.

When comparing rutting performances of the WMA project on I 25 P with the HMA control project on I 25 M, it can be seen from Figure 53 that the difference of rut depths between WMA and HMA pavements are small.

PSI VALUES

The average PSI value per mile on each WMA project is shown in Figure 54 (a)-Figure 54 (f) as a map generated by commercial ArcGIS software. PSI value high means pavement condition is good, whereas low PSI indicates pavement deteriorations. It can be seen from Figure 54 (a) to Figure 54 (f) that the overall pavement conditions for all the WMA projects are very good (4.00-5.00) according to Table 10 with the exception of the evotherm project on NM 118 (Figure 54 [c]) and the foaming project on NM 48 (Figure 54 [d]), which are still in acceptable conditions with PSI value between 3 to 4.

For WMA pavements (I 25 P and NM 48) with RAP, it can be seen from Figure 54 (a) and Figure 54 (d) that the pavement condition of evotherm-RAP pavement (I 25 P) is the best among all the evotherm projects, whereas the pavement condition of foaming-RAP pavement (NM 48) is the worst among all the foaming projects. Therefore no definitive conclusion can be drawn on RAP's role in WMA for dictating this combined index PSI.

When comparing PSI of the WMA project on I 25 P with the PSI value of HMA control project on I 25 M, it can be seen from Figure 54 (a) that the condition of the HMA pavement is better than the condition of WMA pavement.

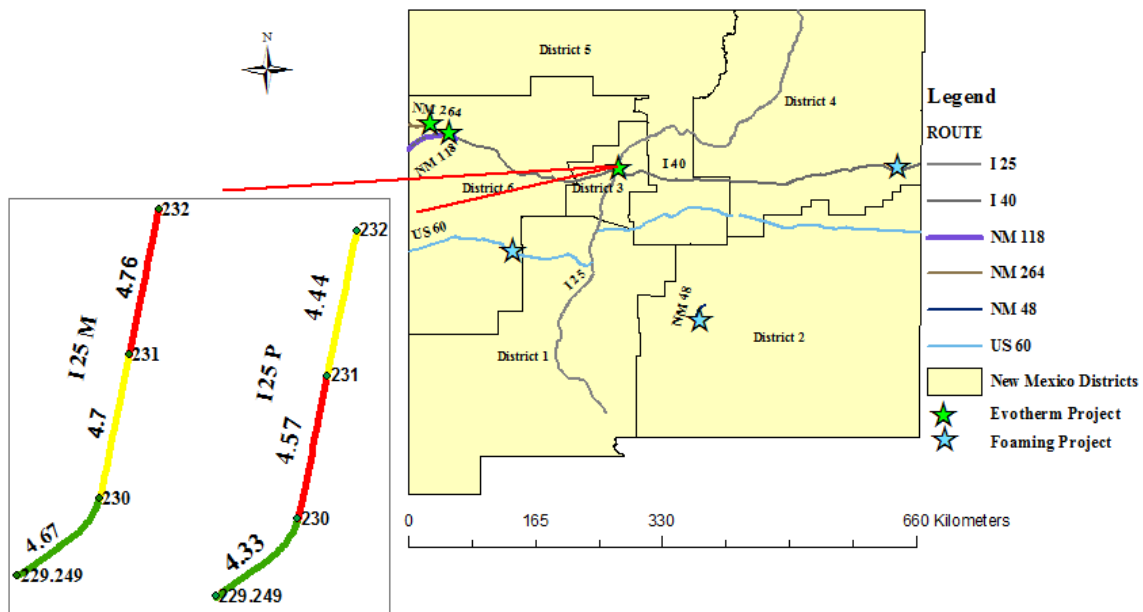

(a) Average PSI Value per Mile on I 25 (Evotherm Pavement).

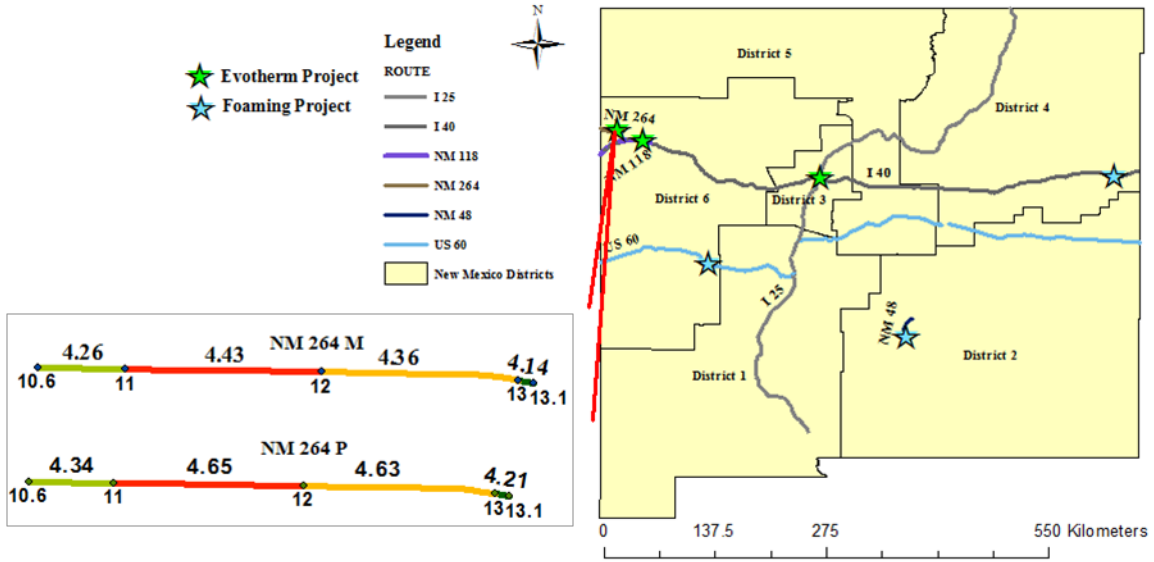

(b) Average PSI Value per Mile on NM 264 (Evotherm Pavement)

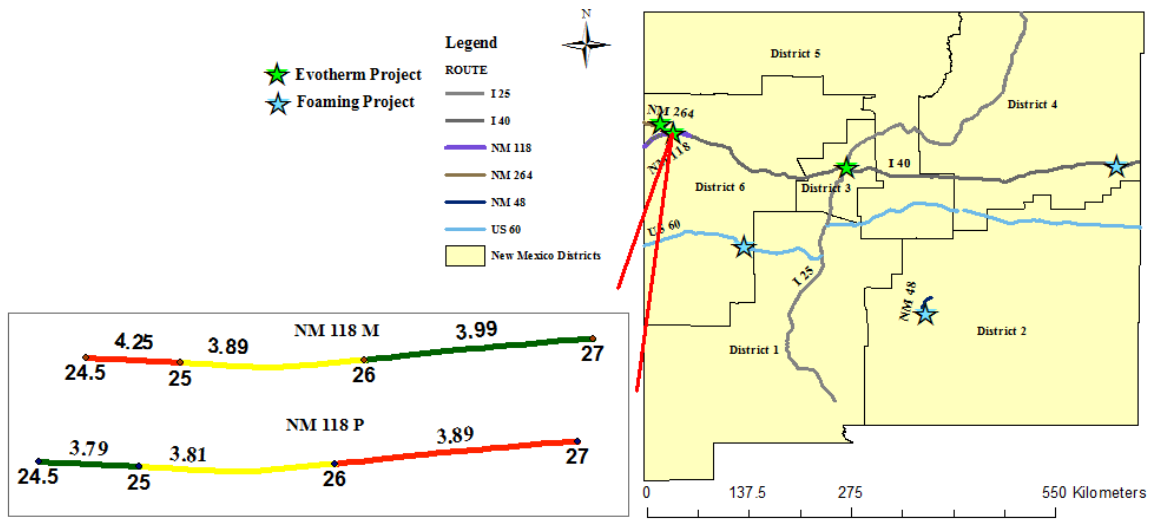

(c) Average PSI Value per Mile on NM 118 (Evotherm Pavement)

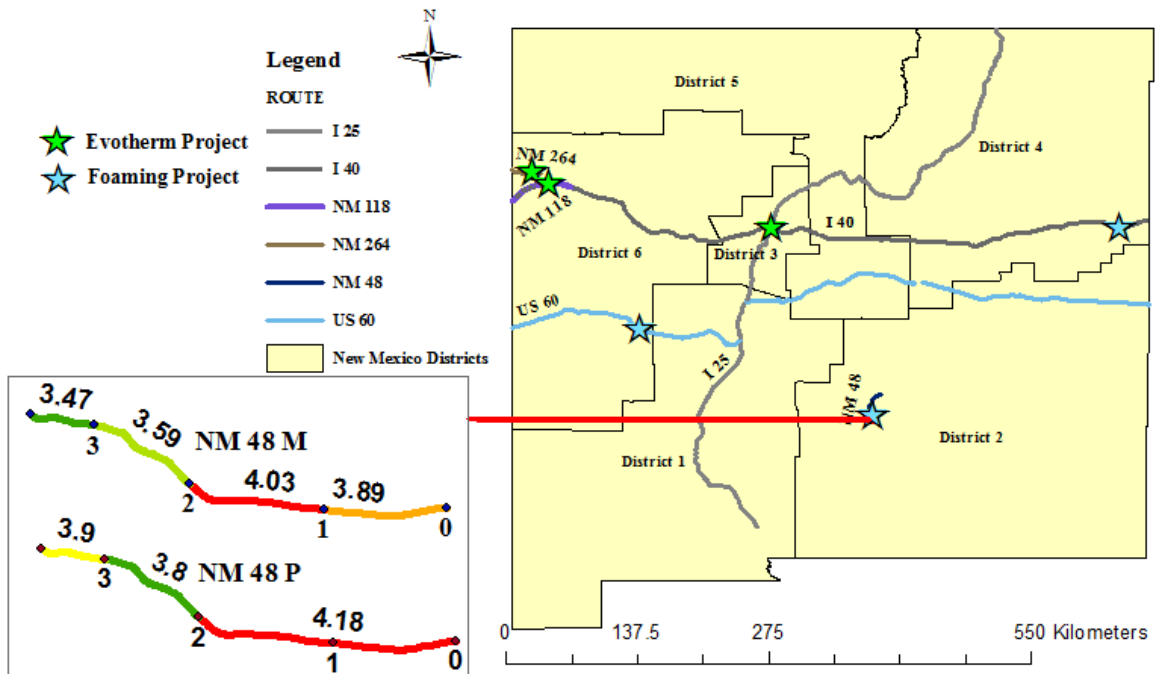

(d) Average PSI Value per Mile on NM 48 (Foaming Pavement)

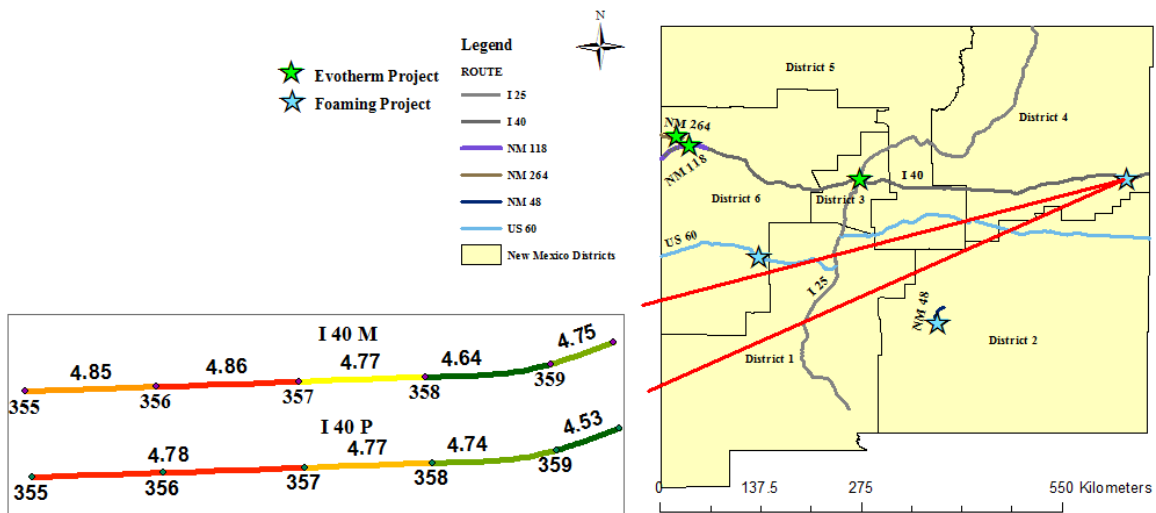

(e) Average PSI Value per Mile on I 40 (Foaming Pavement)

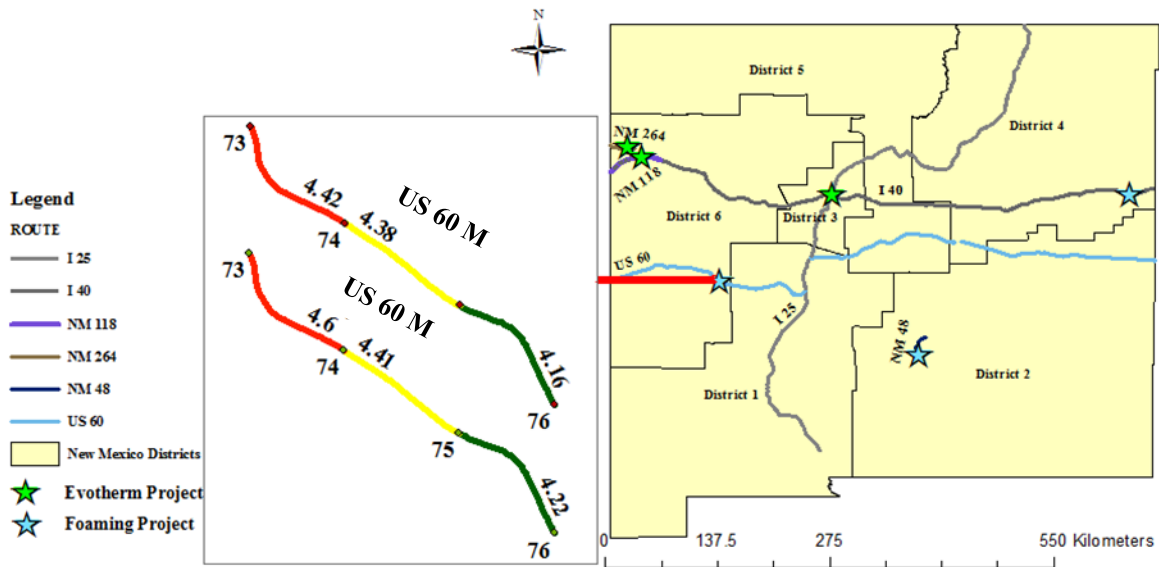

(f) Average PSI Value per Mile on US 60 (Foaming Pavement)

FIGURE 54 Average PSI Value per Mile for Each WMA Project.

REMARKS FROM PAVEMENT MANAGEMENT DATA ANALYSIS

The following conclusions can be made:

- The average IRI of all six WMA pavements are within the acceptable IRI values of 170. The difference in IRI values between evotherm WMA and HMA control pavements is not significant. For all the WMA projects, there are no bleeding, edge cracking, and patching observed with the exception of one evotherm project with bleeding distress and one foaming project with edge cracking and patching distress. The distress rates for these three types of distresses are very low with severity 1 and extent 1. The raveling and weathering distress rate for all the WMA projects and one HMA project are the same with severity 1 and extent 3.
- For most distresses, the differences between WMA pavements with RAP and WMA pavements without RAP are not obvious from this study, except longitudinal cracking of WMA with RAP pavements are less than that of the WMA pavements without RAP.
- Overall, foamed WMA pavements have performed better than the evotherm WMA pavements except for fatigue life. HMA pavement has performed better than WMA pavements.
- The conditions of the evotherm WMA pavement are found to be worse than those of the HMA control pavement. Finally, it can be concluded that HMA performed better than foamed WMA, which performed better than evotherm WMA.

THIS PAGE LEFT BLANK INTENTIONALLY

REVIEW OF WMA PERFORMANCES

A literature review on the laboratory testing of WMA's material properties and performance is conducted. The common concerned issues related to laboratory tests for WMA researches can be summarized as volumetric properties, rutting, modulus, fatigue cracking, thermal (low-temperature) cracking, moisture susceptibility, and workability and compactability. Other particular concerns associated with WMA include RAP incorporation, oxidative aging of WMA, and performance of WMA OGFC, etc.

MIX DESIGN TESTS

National Cooperative Highway Research Program (NCHRP) Project 09-43 concluded that a separate WMA mix design procedure is not necessary (5). However, some modifications to the Superpave mix design procedure (AASHTO R 35) were recommended. Some of the modifications are discussed below:

Laboratory Mixer

NCHRP Project 9-43 required that either a planetary or a bucket mixer should be used to prepare mixes in the laboratory. The mixing times were established by planetary mixer. However, the mixing times for bucket mixers should be determined by coating evaluation. Later NCHRP Project 9-47A confirmed that using the same 90-second mixing time of planetary mixers for bucket mixer can guarantee sufficient coating (5, 63).

NCHRP Project 9-43 suggested a laboratory scale asphalt foaming device to simulate plant WMA foaming processes. NCHRP Project 9-47A states that an option of using mix produced during a trial run at an asphalt plant should be included, if a laboratory foaming system is not available (5, 63).

Mix Volumetrics

NCHRP Project 9-43 described the specimen fabrication procedures for individual WMA technologies. However, it did not specify that lab-produced WMA specimens should be used in the volumetric design process. Based on this, NCHRP Project 9-47A conducted further research and concluded that the traditional volumetric criteria of selecting a mix's optimum asphalt content should be undertaken per Superpave mix design of the AASHTO R 35 (63).

NCHRP Project 9-47A evaluated thirteen WMA mixes, and all of them were designed as HMA and produced using WMA technologies. Ten of these mixes were used for NCHRP Project 9-43's mix design verifications. Field-measured gradations were matched as closely as possible to lab-measured gradations and the HMA control sections were used to determine the difference of optimum asphalt content between WMA and HMA. A summary of the research findings are given below (63):

- Binder absorption: Both plant- and lab-produced mixes showed that the average binder absorption of WMA is lower than the binder absorption of HMA. However, tests on WMA

and HMA cores after one and two years concluded that there were no substantial differences in binder absorption, suggesting that further binder absorption in WMA mixes occurs over time. This can lead to the certain conclusion that there should not be any reduction in asphalt content due to lower absorption for WMA mix design.

- Pavement densification: It is known that the majority of pavement densification under traffic occurs within one to two years after construction. In addition, one might assume that WMA pavement would experience excessive densification in the wheel paths, and this could require lower asphalt content in the mix design. However, the study of NCHRP Project 9-47A showed that the average densities for one- and two-year cores of WMA pavements were similar or even lower than those for the HMA pavements. The result indicates that the WMA pavements do not suffer over-densifying under initial traffic.
- Interaction with compactability: The compactability of WMA mix was better than the HMA control mix, which is determined by gyration ratio at the optimum asphalt content, which is the ratio of the gyrations to 92% relative density at the lower temperature to the higher temperature. NCHRP Project 9-47A indicated that gyration ratio of compactability and in-place density have a poor relationship, and compactability is dependent on asphalt content. A reduction in asphalt content could negate the compaction benefits associated with WMA.

For the mixture volumetric properties, NCAT evaluated three DOTs' field trials of WMA including Missouri State, Ohio State, and Wisconsin State (64-66). For all these three studies, both WMA and HMA control mixes were used the same materials. Evotherm ET (chemical additive), Sasobit (Organic additive), and Aspha-min (water-containing foaming process) processes were used for the WMA projects in Missouri State and Ohio State. Evotherm ET and Sasobit were used for the WMA project in Wisconsin State. All the field specimens (including WMA and HMA control) were compacted to determine mixture volumetric properties using SGC according to AASHTO T 312. Specimens are separated into two sets with one set compacted on site, and one set compacted from mix reheated (laboratory). The mix for the specimens compacted on site was placed in an oven for approximately 30 minutes to account for heat loss that occurred between sampling and splitting (64). Air voids test results were obtained by all the three studies. The results showed that air voids of the reheated specimens are different from the hot (on site) specimens. For the studies of Missouri State and Ohio State, the air voids of the hot specimens were higher than the reheated specimens, while an opposite result was obtained by the study of Wisconsin State. This may be attributed to the different SGCs being used to compact hot and reheated specimens and different time of day the specimen was obtained.

An analysis of variance (ANOVA) was conducted on the compaction data to determine if the different WMA technologies had a significant effect on the compaction of specimens produced in the laboratory for all the three studies. Results from the analysis concluded that the WMA technology, whether or not the specimens were compacted hot or reheated, and the time of day when the specimen was obtained were all significant factors in the relative density of the laboratory compacted specimens (64-65). A Dunnett's test was performed on the ANOVA results to determine how much inclusion of the different WMA technologies reduced the void content of the compacted specimens without reheating. Laboratory air voids for the WMA sections in Missouri State, on average, 0.6% higher (Evotherm ET) to 0.9% lower (Sasobit) than

the control section, at a compaction temperature of 250°F (121°C) for specimens compacted at the plant without reheating (64). There were average 0.7% to 1.2% lower air voids for the WMA sections in Ohio State than the control section at a compaction temperature of 250°F (121°C) (65). Laboratory air voids for the WMA sections in Wisconsin State were statistically lower for the Evotherm ET and statistically the same for the Sasobit at a compaction temperature of 250°F (121°C) (66). The research in Missouri State also included the air void study, asphalt content study (AASHTO T 164), and gradation analyses (AASHTO T 30) of WMA and HMA control specimens under different mixing and compaction temperatures. Its study also concluded that the SGC was relatively insensitive to temperature (64).

Laboratory Testing Protocols

NCHRP project panels 9-43, 9-47, and 9-49 in conjunction with the AASHTO Highway Subcommittee on Materials, the Federal Highway Administration, and the National Asphalt Pavement Association sponsored a “Workshop to Coordinate Key WMA Research Projects” in 2011. A core set of criteria, methods, and protocols for WMA studies was proposed for WMA and they are listed in Appendix C: Table C1 lists field project selection criteria; Table C2 presents specimen preparation methods; Table C3 shows conditioning methods for laboratory-mixed laboratory-compacted (LMLC) specimens, plant-mixed laboratory-compacted (PMLC) specimens, and plant-mixed field-compacted (PMFC) specimens; Table C4-C7 provides performance testing for LMLC, PMLC, and PMFC specimens and conditioning for these types of specimens, respectively; and Table C8 lists aggregate and binder testing (67).

RUT TESTING

Rutting resistance may be a concern for certain WMA technologies, since lower mixing and compaction temperature for WMA cause the binder in WMA to age less than the binder in conventional HMA, which indicates that the stiffness of WMA binder may be lower than HMA binder and, in turn, may cause rutting problems after paving.

To date, there are mainly three test methods to evaluate rutting resistance of WMA including asphalt pavement analyzer (APA) test, Hamburg Wheel Tracking Device (HWTD) Test, and Flow number (FN) test.

Asphalt Pavement Analyzer (APA) Test

In APA, rutting susceptibility of mixtures is assessed by placing a beam or cylindrical specimens under repetitive wheel loads and measuring permanent deformation. Figure 55 is the APA. The APA features an automated data acquisition system, which obtains rutting measurements (permanent deformations) and displays these measurements in a numeric and/or graphical format (68). Though some states have done some WMA research using APA, data from this device have become questionable recently. Because the vertical load applied by the pneumatic pressure in APA, data are highly variable. Many states have already moved away from APA. A summary of the rutting resistance evaluation conducted by stat DOTs using APA are as follows.

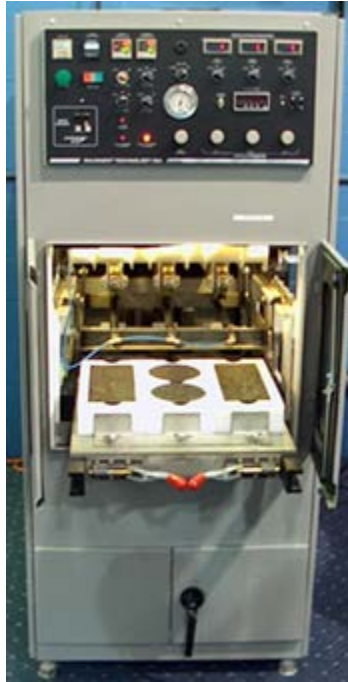

FIGURE 55 Asphalt Pavement Analyzer (APA)

Alaska DOT assessed the rutting resistance of WMA project using Sasobit (organic additive) conducted in Southeast Alaska over traditional HMA. The laboratory results showed that Sasobit improved rutting resistance of WMA binder and mixes. For LMLC specimens, the increase of Sasobit content improved rutting resistance of mixtures. In addition, the rutting depth of the field-cored specimens was higher than that of laboratory specimens with same Sasobit content (68). Similar results were obtained from Missouri State's and Wisconsin State's researches on Sasobit additive study (64, 66).

Using APA, Alabama DOT evaluated WMA additive Evotherm DAT and Michigan DOT evaluated three WMA technologies including water containing foaming processes (Aspha-min and Advera), water based foaming process, addition of organic additive (Sasobit), and addition of chemical additive (Cecabase RT). The rut test results of all these two researches indicated that the WMA was more susceptible to rutting than the HMA (69-70).

Using APA, Florida DOT evaluated three WMA projects using Aspha-min (water containing foaming process), Evotherm DAT (chemical additive), and Astec Double Barrel Green (water based foaming process), respectively. Results showed that there is no significant difference in laboratory performance or in measured pavement condition survey data for rutting evaluation between the WMA and HMA control sections (71). Similar results were obtained from Ohio DOT'S research on Sasobit and Aspha-min WMA projects, which showed the measured rut depths were statistically equal to the HMA control (65). The laboratory study on field cores of Sasobit WMA in Virginia DOT also proved that the WMA showed almost equal performance to the HMA in term of rutting potential (39).

Using APA, Georgia DOT evaluated Evotherm 3G, Rediset, and Cecabase RT (all chemical additives) WMA processes. Results from the APA rutting tests indicated that all WMA and

HMA control mixes meet the Georgia DOT acceptance requirements. Evotherm 3G WMA mix has a slightly higher rut depth value compared with other WMA and HMA control mixes (72). Similar results were obtained from Ohio State's and Wisconsin State's researches on Evotherm ET WMA mix, which resulted in statistically higher measured rut depths than the HMA control mix (65-66).

Hamburg Wheel Tracking Device (HWTD) Test

Hamburg Wheel Tracking device (HWTD) applies static steel wheel loads on the specimens in a heated bath and the deformation is measured as a function of the number of loading passes (Figure 56). *AASHTO T 324, Standard Method of Test for Hamburg Wheel-Track Testing of Compacted Hot-Mix Asphalt (HMA)*, is recommended for both rutting resistance testing and moisture susceptibility testing, according to the summary of "Workshop to Coordinate Key WMA Research Projects" sponsored by NCHRP project panels 9-43, 9-47, and 9-49 in conjunction with the AASHTO Highway Subcommittee on Materials, the Federal Highway Administration, and the National Asphalt Pavement Association (67). Most state DOT's WMA researches are now using HWTD test to evaluate rutting and moisture susceptibility of WMA mixes.

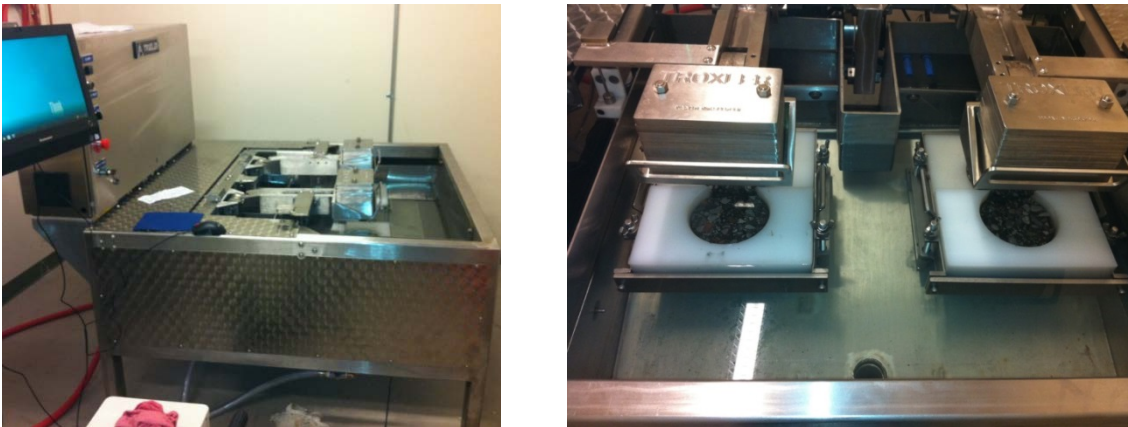

FIGURE 56 Hamburg Wheel Tracking Device (HWTD).

Missouri DOT used HWTD tests to evaluate rutting performance of Sasobit (organic additive), Aspha-min (water containing foaming process), and Evotherm ET (chemical additive) WMA mixes (64). Results indicated improved rutting performance for all these three WMA technologies. The reasons for this are that the addition of the Sasobit most likely improved the stiffness of the mix when the wax crystallized. The Aspha-min may have acted as additional fines to create a mastic, resulting in a stiffer binder to aid in resisting rutting. The improved rutting resistance in the laboratory for the Evotherm ET most probably was caused by another mix phenomenon, since Evotherm ET does not stiffen the binder (64).

Texas DOT used HWTD tests to evaluate rutting resistance of WMAs using an organic wax based additive (Sasobit), a moisture based additive which is intended to improve workability by micro-foaming (Advera), and two chemical technologies (Evotherm 3G and Rediset WMX).

Results showed the rutting resistance of WMA is relatively lower than the rutting resistance of a similar HMA, which is primarily attributed to reduced aging (73). Most WMA additives used in this study even exacerbate the reduced rutting resistance. However, findings from this study indicated that organic wax based additives such as Sasobit can compensate for the reduced rutting resistance with certain (but not all) binders (73).

Washington DOT evaluated the rutting performance of four different WMA technologies including three water based foaming processes (AQUABlack, Gencor, and Water Injection), one organic additive (Sasobit). Results from HWTB tests showed that the AQUABlack and Sasobit WMAs performed equally to the corresponding HMA controls. However, the rutting performance of the Gencor and Water Injection mixes were adversely affected. But, even though the rutting performance for the WMA was not as good as the HMA, the WMA did not even approach the failure limits for rutting in the Hamburg (42).

Flow Number (FN) Test

This test method is recommended by NCHRP 9-43 according to AASHTO TP 79. FN test data was used for pavement ME design model development. FN test can be done using a Material Testing System (MTS). Figure 57 shows the MTS. In MTS, a specimen is subjected to a repeated compressive load pulse at a specific test temperature during a flow number testing. The consequential permanent axial strains caused by each load pulse are measured and used to calculate the flow number, or the point where the specimen exhibits uncontrolled tertiary flow (74).

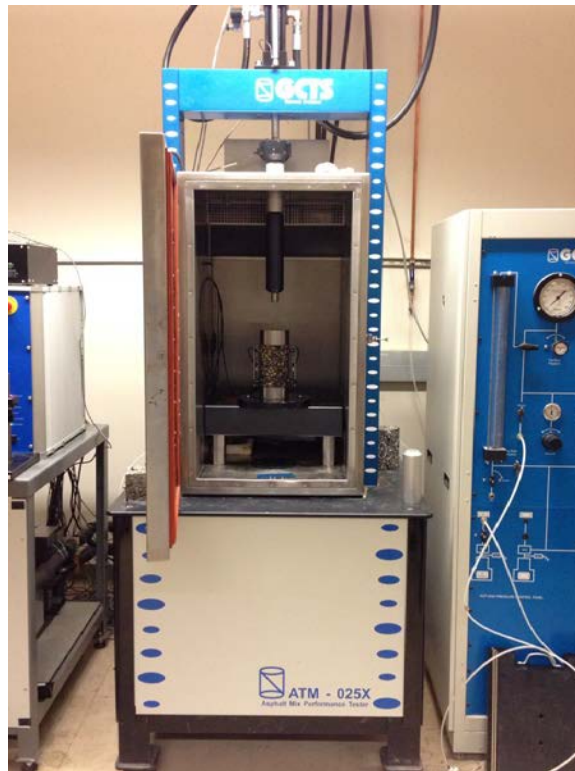

FIGURE 57 Photographs of MTS at UNM.

The FN test conducted by Alabama DOT's research (mentioned above) concluded that the FN test supported the rut susceptibility findings of APA and HWTD tests, which both indicated that the WMA was more prone to rutting than the HMA control (69). Similar conclusion were obtained by Iowa DOT's investigation with three WMA technologies including foaming process, organic additive (Sasobit), and chemical additive (Evotherm) by lots of PMLC specimens, PMFC specimens, and field cores. The results of FN tests indicated that on average, WMA has lower FNs when compared with the HMA control unless the reduced stiffness is offset by recycled material added to the mixture (75).

The FN tests were also conducted by Michigan DOT's research as mentioned above (70). It first evaluated the FN testing for different foaming methods (Aspha-min, Advera, and water foaming). Results showed that lower FNs for all the foaming WMA specimens than the HMA control due to lesser aging of WMA during the production. In addition, the amount of water content used to foam WMA and the mixing/compaction temperature did not affect the FN of WMA (70). The FN of WMA with chemical additive (Cecabase RT) was also lower than the HMA control. However, the FN of WMA with organic additive (Sasobit) was not significant different from the HMA control. This result is in accordance with previous rutting studies by APA tests and HWTD tests.

Major Differences among APA, HWTD, and FN Tests

The major difference between the FN test and one of the other rutting resistance tests like APA or HWTD is the fundamental mechanical nature of the FN test and that testing results can be used in new Pavement ME Design software to estimate the performance of a pavement constructed with the tested mixture. This fulfills the underlying goal to link mixture design with structural analysis by using the same tests for both mixture evaluation and structural design. In addition, FN test has received national support instead of regional support during its development (74). For the differences between APA and HWTD tests, the research conducted by Shiwakoti (2007) compared the APA tests with HWTD tests by investigating rut depths of HMA with the addition of anti-stripping additives. The use of the additives showed the benefits in the reduction of the rut depth in some cases of the APA tests but not in all. However, most of the HWTD test results showed that the benefits in the later stage of the tests, although in earlier stage, the specimens with the additive had larger rut depths than those without any additive (76).

DYNAMIC MODULUS TESTING

In dynamic modulus testing, a specimen is subjected to continuous sinusoidal, stress-controlled loading at a specified frequency and temperature. Dynamic modulus is measured as the ratio of the peak stress and peak strain. The modulus of asphalt concrete cannot be described by a single value, since the response of asphalt materials depends on both temperature and loading rate, the latter representing traffic speed. A dynamic modulus master curve is developed by an equation that gives the modulus of an asphalt concrete mixture for any combination of temperature and loading rate (74).

The dynamic modulus test conducted by Alabama DOT indicated that the HMA is stiffer than the WMA (69). This conclusion have also been proved by the Colorado DOT's dynamic modulus testing on water containing foaming process (Advera), organic additive (Sasobit), and

chemical organic (Evotherm DAT) (48). Similarly, the dynamic modulus test results of Michigan DOT's WMA research indicated that for most tested WMA technologies (Cecabase RT, Advera, and Water Foaming), the dynamic modulus are lower than the HMA dynamic modulus. However, the dynamic modulus of Sasobit WMA showed no significant differences from the HMA control and the value of dynamic modulus of Aspha-min WMA was comparable to the HMA control (70). The Sasobit WMA result of Michigan DOT is accordance with the result obtained from Missouri DOT's research, which also indicated that the Evotherm ET WMA was not statistically different than the HMA control (64). Opposite result was obtained about the dynamic modulus of Aspha-min WMA from Missouri DOT's study, that is, the Aspha-min produced statistically lower dynamic modulus results (64).

Other test methods that have potentials for measuring modulus of WMA include indirect tension resilient modulus and spectral analysis of seismic waves (SASW). These two methods were recommended for testing the modulus of PMFC specimens by the "Workshop to Coordinate Key WMA Research Projects" (67).

FATIGUE CRACKING TESTING

Fatigue cracking resistance of both WMA and conventional HMA mixtures is strongly related to the aging of asphalt binder. Oxidative aging of asphalt binders is known to increase the stiffness of the binder, reduce its ductility, and possibly negatively affect its resistance to fatigue (73). There are several methods used by state DOTs to evaluate fatigue cracking of WMA.

Dynamic Mechanical Analyzer (DMA)

This method is to use DMA to evaluate the resistance of the Fine Aggregate Matrix (FAM) portion of asphalt mixtures to cracking and moisture damage. The steps in FAM specimen production include preparing a SGC specimen, trimming the SGC specimen into smaller size DMA specimens, and gluing and installing DMA specimens with DMA device. For fatigue life testing, the DMA applies cyclic, torsional strain-controlled loading to cylindrical asphalt mastics until failure (77). UNM does not possess DMA yet.

Texas DOT adopted this method to evaluate WMA mixtures' fatigue life (from dry to wet). There were three WMA technologies, including water containing foaming process – Advera, organic additive – Sasobit, and chemical additive – Evotherm DAT (50). Fatigue life results from DMA tests indicated that all the WMA mixture types exhibited a significant improvement in fatigue for the dry tests. The average wet fatigue life for the WMA mixtures was also greater than the HMA (73).

Beam Fatigue Test (BFT)

The current test method for beam fatigue testing is ASTM D7460 and/or AASHTO T-321. This test specimen is subjected to repeated flexural bending force to obtain its fatigue life, and this test is also known as the four point flexural fatigue test. Specimens are first compacted in a beam compactor and then cut to required dimensions (39). Figure 58 shows BFT apparatus in UNM's Pavement Laboratory.



FIGURE 58 Beam Flexural Fatigue Apparatus by GCTS Testing Systems.

Georgia DOT performed BFTs on four mixes following the AASHTO T321-07 standard. The rankings of cycles to failure from high to low among four mixes are Cecabase RT mix (chemical additive), Rediset mix (chemical additive), HMA control mix, and Evotherm 3G (chemical mix). ANOVA results indicated that the cycles to failure among the four mixes showed a statistical difference at a moderate significant level (72). Similarly, BFTs were conducted by Michigan DOT with three main WMA technologies – foamed WMA (Aspha-min, Advera, and free water system), organic additive (Sasobit), and chemical additive (Cecabase RT). Results showed that most of the WMA has higher fatigue life (70).

The fatigue life study on only Sasobit WMA (organic additive) was conducted by Virginia DOT in accordance with AASHTO T321 as well (39). Fatigue results indicated that the HMA performed slightly better at lower strains than the WMA; however, the performance of the mixes appeared nearly equal at higher strains. In addition, the WMA produced at high temperature appeared to perform slightly better than the WMA produced at low temperatures (39).

Overlay Test

Overlay test is used to evaluate a mixture's resistance to reflection cracking. The schematic of overlay tester is shown in Figure 59. The overlay tester is an electro-hydraulic system that applies repeated direct tension loads to specimens (78). It is generally considered that dense-graded mixtures should last a minimum of 300 cycles for an acceptable field performance (50).

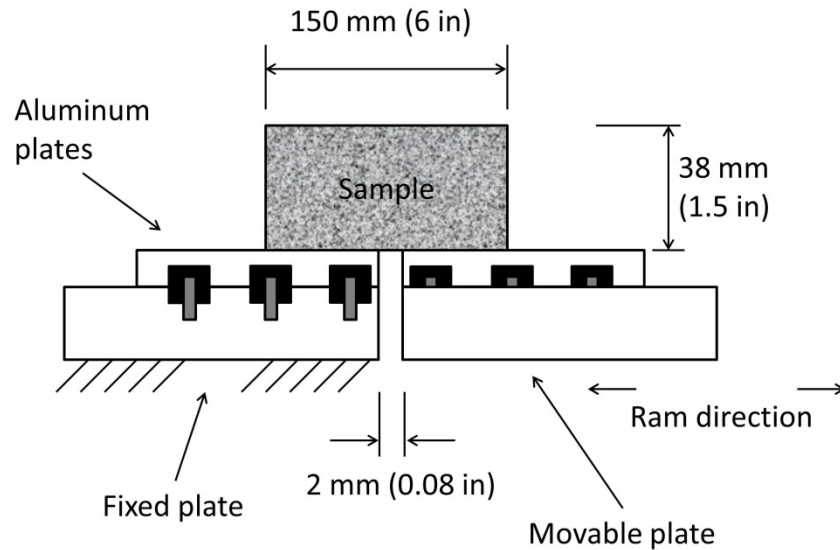

FIGURE 59 Schematic of Overlay Test (50).

Texas DOT conducted an overlay test to evaluate Advera (water containing foaming process), Sasobit (organic additive), and Evotherm DAT (chemical additive) WMAs. Results of this test indicate that Advera and Evotherm DAT WMA have more cracking resistance compared to the HMA control mixtures. Sasobit WMA exhibited nearly equal performance to the HMA control mixture (50).

LOW TEMPERATURE CRACKING TESTING

Low temperature cracking of asphalt pavement is associated with cold temperature during the winter months. The common test methods to evaluate low temperature cracking resistance are indirect tension test (IDT) and semi-circular bending test.

IDT Test

In IDT test, an asphalt specimen is loaded diametrically to determine the tensile creep stiffness and tensile strength according to the AASHTO T 322.

Alaska DOT assessed low temperature cracking of WMA using Sasobit (organic additive) conducted in Southeast Alaska over traditional HMA. Results from IDT tests of all laboratory prepared specimens showed that tensile strength decreases with an increase in Sasobit content at all testing temperatures, which indicated degraded resistance of Sasobit WMA to thermal cracking (68).

Washington DOT evaluated the thermal cracking performances of four different WMA technologies including three water based foaming processes (AQUABlack, Gencor, and Water Injection), one organic additive (Sasobit). The results are mixed. The Gencor and water injection mixes showed more resistance to low temperature cracking than the HMA control mixes. However, the Sasobit and AQUABlack mixes were comparable to the HMA control mixes in regards to resistance to low temperature cracking (42).

Semi-Circular Bending Test

Although IDT is the most widely used method, it does not directly address crack propagation and post-peak behavior of the tested materials. These disadvantages can be improved utilizing fracture mechanics concept and tests. The Semi-Circular Bending (SCB) test configuration (Figure 60) has been adopted nowadays by many researchers in asphalt pavement community, due to the straightforwardness in specimen preparation from the gyratory compacted cylinders or field core specimens (79).

Figure 60 shows the schematic of SCB test. A semi-circular specimen symmetrically supported by two fixed rollers is loaded in an environmental chamber. A vertically mounted extensometer measures the load line displacement (LLD). Crack mouth opening displacement (CMOD) is recorded by a clip gauge. A constant CMOD rate is usually applied to the specimen until failure. The load and LLD is recorded constantly. Results are used to calculate the fracture energy, fracture toughness and stiffness of asphalt specimens at low temperatures (75, 79).

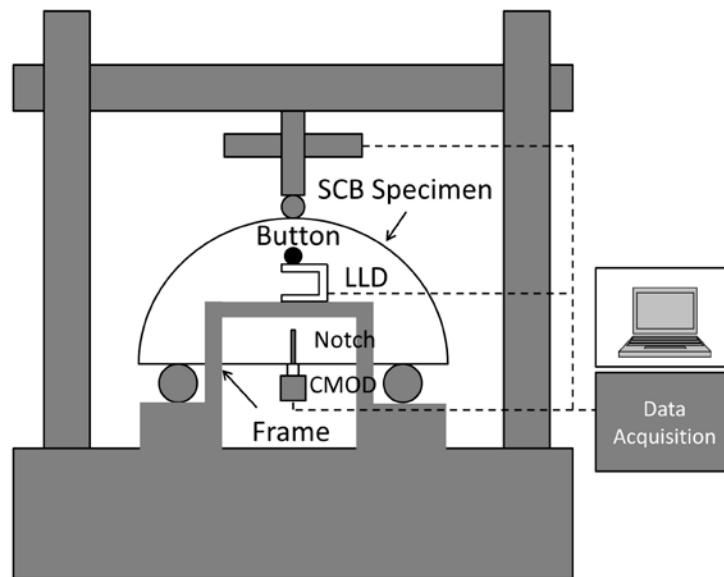

FIGURE 60 SCB Experiment Setup (79).

Iowa DOT has used SCB test to investigate low temperature cracking of WMA mixtures with three WMA technologies including foaming process, organic additive (Sasobit), and chemical additive (Evotherm). The SCB tests did show some good correlations with other measured material properties obtained by the study but the test data was generally too variable for making statistical differences (75). Thus, Iowa DOT recommends further studies to be conducted to understand how to obtain reliable results from SCB tests.

MOISTURE SUSCEPTIBILITY

Moisture damage in asphalt pavements is a national issue because moisture tends to accelerate the presence of other distresses such as bleeding, cracking, rutting, and raveling. WMA may be

more susceptible to moisture susceptibility resulting from incomplete drying of aggregate and differences in aggregate absorption of binder. Therefore, evaluation of moisture susceptibility of WMA is even more important.

NCHRP Project 9-49, *Evaluation of the Moisture Susceptibility of WMA*, conducted a web-based survey. There were 35 agencies responded to the survey. The results showed that 76% percent of the responding state DOTs indicated that their agency specifications included related criteria as part of the HMA or WMA design procedure. The TSR of the AASHTO T 283 is the moisture susceptibility test preferred by 68% percent of the state DOTs. The second preferred test is the HWTD test (AASHTO T 324), with 19% of responses. Other tests, such as the APA (AASHTO TP 63) and the Immersion Compression Test (AASHTO T 165), accounted for only 10% of the responses (80).

Evaluation of the Moisture Susceptibility of WMA by NCHRP Project 9-49

According to NCHRP report 763, four field sections in Iowa, Texas, Montana, and New Mexico states were selected based on the considerations of climate, aggregate type, binder type, inclusion of RAP or RAS, and WMA technologies (Evotherm and Foaming for Iowa, Texas, and New Mexico states; Evtherm, Foaming, and Sasobit for Montana state). Three test methods were selected to quantify the mixture stiffness in dry and wet conditions and the loss of strength and stiffness after moisture conditioning. They are IDT strength tests in dry conditions and after moisture conditioning to determine TSR, HWTD tests to understand mixture resistance to both moisture susceptibility and rutting, and determination of resilient modulus (M_R) ratio of wet to dry conditioned specimens (80).

Results show that prior to summer aging, WMA can be more susceptible to moisture damage in early life as compared to HMA, but equivalent performance is found after a summer of aging. The use of anti-stripping additives may reduce the moisture susceptibility. Thus, actions such as adding anti-stripping additive to WMA mixes or ensuring summer aging of WMA pavements prior to wet and cold winter conditions should be considered to prevent moisture-related pavement distresses from occurring (80). Generally, the WMA field projects in the selected four states are performing well to date.

WORKABILITY AND COMPACTABILITY OF WMA

The workability for asphalt mixtures is defined as the asphalt mixture property that describes the ease with which the asphalt mixture can be placed, worked by hand, and compacted to the desired mat density. The compactability of asphalt mixtures is often used to describe how easy or difficult mixture is to compact on roadway.

Bennert et al. assessed the workability and compactability of WMA in New Jersey. They evaluated the potential use of asphalt binder tests to rank the workability and compactability of asphalt binders modified with warm mix additives, potential use of asphalt mixture tests to rank the workability and compactability of WMA mixtures, and tried to find a test procedure to evaluate and rank workability and compactability of asphalt mixtures modified with WMA technologies. The asphalt binders evaluated in the study were performance grade (PG) 76-22 binders with 11%-13% styrene butadiene styrene (SBS). Three WMA technologies, Evotherm

3G, Rediset, and Sasobit, at varying dosage rates were evaluated after blended with asphalt binder at 385 °F (196 °C) for 1 h on a low shear mixer. Binder test results showed that minimal changes occurred in the PG 76-22. In some cases, the high-temperature PG grade of Evotherm 3G and Rediset binders slightly decreased, whereas slight increases in high-temperature PG of Sasobit binders were found (81).

The asphalt binders preblended with the different WMA additives were evaluated under both asphalt binder related tests and also asphalt mixture tests. Each of the asphalt binder was used to construct a 12.5-mm, coarse graded, Superpave mixture (81).

The asphalt binder tests were conducted to assess their potential for indexing and ranking the workability of WMA and additives. Rotational viscosity test (AASHTO T316) was conducted to determine mixing and compaction temperatures. Also NCHRP Project 9-39 test was conducted to determine mixing and compaction temperatures (81-82). Both the rotational viscosity test and NCHRP 9-39 test methods resulted in unrealistically high mixing and compaction temperatures due to some of the additives not influencing the general viscosity properties of asphalt binder such as Evotherm 3G, as well as the NCHRP 9-39 test method artificially restricting the minimum mixing and compaction temperature attainable due to the equations used in their respective calculations (81).

The lubricity test is used to better simulate realistic binder film thickness between aggregates, which is based on the concept of thin-film rheology at film thickness between 25 microns to 500 microns. First lubricity test was conducted by Mathy Technology and Engineering Services to evaluate the steady state flow of asphalt binders in the dynamic shear rheometer (DSR) at thin-film thickness (13). The lubricity test for asphalt binders compared satisfactorily to the asphalt workability device (AWD) and the Marshall compactor tests for mixtures regarding ranking the workability and compactability of the asphalt binders. This might be due to the more realistic film thicknesses of asphalt binder for the lubricity test. It is recommended that the lubricity test can be used for WMA additive selection and dosage rate determination. This testing can be used during the WMA mix design phase, as well as a possible quality control tool during mixture production (81).

Each of the asphalt binder studied was mixed with the aggregates to construct a 12.5-mm Superpave mixture which were then evaluated for workability and compactability. Three devices used are: asphalt workability device (AWD), Marshall compactor, and gyratory compactor. The gyratory compactor were somewhat insensitive at compaction temperature between 300 °F to 255°F (149 °C to 124 °C), in terms of compacted densities. However, a clear difference was seen in the rate of compaction as defined by the height per gyration to achieve a specified density. The Marshall compaction method and the AWD provided rankings of asphalt mixture workability that were consistent with field observations. This indicated that the Marshall compaction procedure is capable of evaluating different WMA additives and dosage rates during the WMA mix design phase (81).

NCHRP Project 9-43, *Mix Design Practices for Warm Mix Asphalt*, also studied the testing method and procedure for the workability and compactability of WMA. For the workability study, researchers selected four devices for the Phase I screening test, including UMass Workability Device, Nynas Workability Device, University of New Hampshire Workability

Device, and Gyratory Compactor with Shear Stress Measurement. The screening study was to investigate the effects of temperature and WMA additive on the workability of the mixtures. It consisted of performing workability test on a single mixture produced with three binders: PG 64-28 control, PG 64-28 with Sasobit, and PG 64-28 with Advera. It was concluded that devices that measure the torque during mixing or the force to move a blade through loose mix could not detect differences between HMA and WMA mixtures at normal WMA production temperatures. However, differences could be detected at lower temperatures related to compaction. Although the workability study found that it was possible to measure differences in the workability and compactability of WMA as compared to HMA, the differences were only significant at temperatures below typical WMA production temperatures. This indicated that the evaluation of coating at the production temperature is sufficient. Nevertheless, compactability of WMA should be evaluated by using the gyratory compactor to determine the gyrations to 92% relative density at the planned field compaction temperature and a second temperature that is approximately 54 °F (30 °C) lower than the planned field compaction temperature. A maximum increase in gyrations of 25% is recommended when the compaction temperature is reduced. This procedure should be sufficient for an assessment of the effect of temperature on the compactability of the WMA mixture (5).

WMA WITH RAP INCORPORATION

RAP and WMA have become the primary methods for enhancing sustainability in the asphalt industry in recent years. To further enhance sustainability benefits, asphalt producers have begun using RAP and WMA in combination. Durability of RAP mixture had been a concern when high percentage of RAP is used, which would result in increasing cracking potential by the increase of mixture stiffness. Some researchers believe that the reduced aging in the asphalt binder associated with lower production temperature in WMA mixtures allows for the incorporation of higher amounts of RAP (83). Fundamentally, the stiffer RAP binder can be counterbalanced by virtue of the less-aged binder, resulting from the WMA production process, which reduces mixture production and laydown temperatures and hence oxidative hardening and volatilization (83-84).

Doyle et al. (2011) studied the moisture and rutting resistance of WMA-RAP mixture performance. They suggested that moisture and rutting resistance could be improved through the combination of WMA and RAP (85).

Zhao et al. (2012) evaluated the rutting resistance, moisture susceptibility and fatigue resistance of WMA containing high percentages of RAP through laboratory performance tests. The WMA mixtures were plant produced with a commonly-used foaming technology. WMA mixtures contained RAP content ranged from 0 up to 50% (0%, 30% 40%, 50%) with HMA control containing up to 30% RAP. The following laboratory performance tests were employed for the evaluation: asphalt pavement analyzer (APA) rutting test, HWTD test, TSR test, IDT test, and beam fatigue test. Based on the test results, conclusions they made: (i) Rut resistance of WMA was improved with RAP incorporation, and the improvement on WMA was more significant than that of HMA control; (ii) Moisture susceptibility of WMA had been reduced by adding RAP. WMA with high RAP percentage ($\geq 30\%$) exhibited a good resistance to moisture damage; and (iii) WMA containing RAP might have a longer fatigue life than HMA control containing the same content of RAP (86).

Hill et al. (2012) focused on the low-temperature characteristics of WMA-RAP mixtures, meanwhile, considering rutting and moisture resistance to evaluate the overall durability of WMA-RAP mixtures (85). WMA mixtures include four WMA additives: Evotherm 3G (Chemical additive), Rediset LQ (Chemical additive), Sasobit (Organic additive), and Advera (Foaming additive), and three RAP percentage: 0%, 15%, and 45%. Disk-shaped compact tension [DC(T)], IDT creep compliance, and acoustic emission (AE) tests were used for low temperature cracking evaluation. TSR test was used for moisture susceptibility evaluation, and HWTD test was used for rutting resistance evaluation. The test methods are described as follows (84):

The DC(T) test (specified as ASTM D7313) was conducted at -12°C to evaluate the fracture energy associated with a crack propagating perpendicular to the applied load in a material. IDT creep test (AASHTO T 322) was conducted at 0, -12 , and -24°C to measure m -values (relates to the stress relaxation and creep deformation rate of viscoelastic materials). Higher m -value corresponds to more compliant and relaxant asphalt mixtures, which are more resistant to thermal cracking. An AE is defined as a spontaneous release of localized strain energy in a stressed material in the form of transient stress waves. AE test was conducted to gather information related to the initiation and propagation of a crack. TSR tests were conducted on a set of wet and dry AC specimens. The HWTD test was conducted at 50°C to determine rutting and moisture damage of WMA.

The following conclusions were made by Hill et al. (2012):

- The chemical additives improved the DC(T) fracture resistance of WMA mixtures as compared to the HMA control mixture. RAP incorporation led to reduce fracture energy and IDT creep compliance. These results indicated that no matter what WMA additives used, the presence of RAP at low temperatures may lead to increase thermal cracking potential. The testing results from AE test were consistent with the results observed from DC(T) fracture energy and IDT creep compliance. Furthermore, the AE results were sensitive to RAP content and to the additive type used in their study.
- Increased RAP contents led to increased resistance to moisture damage based on the TSR test results, indicating the use of proper RAP incorporation with WMA may be beneficial to avoid moisture damage. In addition, the chemical additive modified WMA mixtures performed the best among the WMA mixtures with respect to TSR moisture resistance due to the inherent anti-stripping capabilities of these chemical additives.
- HWTD test showed that rutting resistance increased with increasing RAP contents in all the WMA mixtures. Sasobit modified WMA mixtures had the best moisture resistance among the WMA mixtures because of the inherent stiffening characteristics of this particular organic additive.

OXIDATIVE AGING OF WMA

Gandhi and Amirkhanian (2008) studied the WMA binder aging characteristics in the laboratory (87). Asphalt mixtures for the evaluation contained two different binder sources (original binders and extracted binders) and two different WMA additives including Asphamin (water-containing

foaming additive) and Sasobit (organic additive). Both WMA and HMA control mixtures were artificially aged in the oven, and binders were extracted for testing. The binders extracted from freshly prepared specimens were considered being short term aged binders and binders extracted from oven aged mixtures were considered being long term aged binders. Tests for binders conducted included viscosity test by rotational viscometer (AASHTO T316), rutting parameter ($G^*/\sin \delta$) for short term aged binders measured by DSR, fatigue parameters ($G^* \sin \delta$) for long term oven aged binders measured by DSR, and flexural creep stiffness and m -value for long term aged binders measured by bending beam rheometer (BBR) to determine the thermal (low-temperature) cracking resistance. Results showed that for the original binders, the binders containing Asphamin and the control binders had significantly similar viscosities, and binders containing Sasobit had significantly lower viscosities compared to binders containing Asphamin and the control binders. For the extracted binders, the viscosities of the binders extracted from WMA were significantly lower than the viscosities of the binders extracted from HMA. Similarly, binder extracted from WMA showed significantly lower $G^*/\sin \delta$ values (lower rutting resistance) compared to binders extracted from HMA. In addition, WMA mixtures used in this study were not more prone to cracking at low temperatures. Thus, the lower mixing and compaction temperatures of the WMA significantly lower the aging in the binders (87).

Banerjee et al. (2012) studied the effect of long-term aging on the rheology of WMA binders (88). The authors focused on four WMA additives: Sasobit (organic additive), Rediset, Cecabase and Evotharm (Latter three are chemical additives). Specimens were first aged by Rolling Thin Film Oven (RTFO) and then long term aging for specimens was conducted at different degrees of aging. The mechanical properties of the asphalt binder specimens were evaluated using frequency sweep DSR tests at different temperature (40 °C, 52 °C, and 64 °C) and ten different frequencies ranging from 0.1 Hz to 25 Hz. A master curve is used to express the rheological properties of asphalt binder as a function of temperature and loading rate. The major findings of this study were: (i) the Rediset WMA binder had the lowest shear modulus, followed by the Evotharm, Cecabase, and Sasobit WMA binders; and (ii) the Sasobit WMA binder had a significantly lower modulus over time as compared to the control binder, and the Rediset WMA binder had the lowest modulus in the short-term as well as over time (88).

Texas Transportation Institute (TTI) evaluated WMA binder oxidative aging. Field aging of both unmodified binder and the same binder with Evotharm additive were simulated using an aging model. Aging was measured in terms of asphalt carbonyl “CA” content and asphalt DSR function. TTI’s study concluded that the unmodified binder showed slightly greater aging, in terms of both binder CA content and DSR function. A review of the binder properties indicated that the difference between unmodified binder and Evotharm modified binder may be primarily due to the slightly lower activation energy of the unmodified binder. Overall the modified and unmodified binders showed similar aging properties and aging differences were modest (89).

PERFORMANCE OF WMA OGFC

Goh and You (2011) characterized the mechanical properties of porous asphalt pavement (same as OGFC) mixtures containing RAP and Advera (water-containing foaming additive) WMA additive using Superpave gyratory compactor and dynamic modulus testing. Four types of porous asphalt mixtures were evaluated including a conventional porous asphalt mixture, a porous asphalt mixture with Advera WMA additive, a porous asphalt mixture

containing 15% RAP, and a porous asphalt mixture containing 15% RAP and Advera WMA additive. Compaction energy index (CEI), permeability, IDT, and dynamic modulus (E^*) of all porous asphalt mixtures were determined (90).

CEI is defined as the area from the eighth gyration to 92% of maximum specific gravity (G_{mm}) under the curve as shown in Figure 61 (91). The lower values of CEI indicate better performance. A too low value indicates the mixture is tender. Permeability testing was used to evaluate the flow rate of water through a saturated specimen. The falling head permeability test was conducted using one-dimensional laminar flow of water. Dynamic modulus testing was conducted according to the AASHTO TP62. Mixtures with higher of E^* values tend to have better rutting resistance. The IDT testing was used to evaluate an asphalt mixture's cracking potential according to the AASHTO T283. A higher tensile strength generally means that asphalt pavement can endure higher strains before it fails (90).

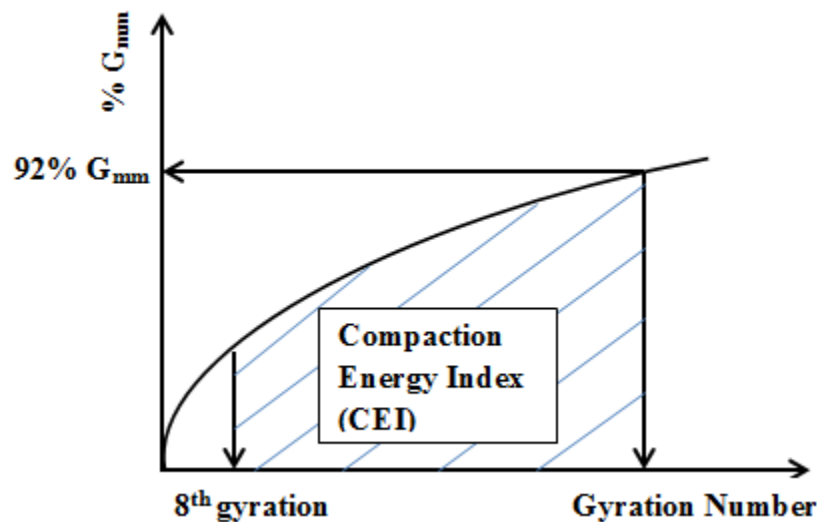

FIGURE 61 Illustration of Compaction Energy Index (90).

Conclusions made by Goh and You's study (2011) included that: (i) from gyratory compactor results, energy used during construction of Advera WMA was lower compared to the HMA control, and the mixtures containing RAP were also found to have higher CEI; (ii) permeability decreases when RAP is used and meets the minimum coefficient of permeability required to achieve sufficient drainage on the road surface, and no solid conclusions can be made between permeability of HMA and WMA; (iii) the E^* of Advera WMA was significantly lower than the HMA control, whereas the E^* value was higher for porous asphalt mixture containing RAP than the HMA control and the E^* decreased slightly with the addition of Advera additive to the porous asphalt mixture containing RAP; and (iv) WMA had lower IDT value due to poor coarse aggregate coating during the low temperature mixing process. However, WMA with RAP had significantly higher tensile strength than HMA control that contains RAP. Therefore, a higher RAP percentage could be used to design porous asphalt mixtures. Indeed, RAP incorporation could offset the disadvantage (lower tensile strength) due to lower mixing temperature for WMA mixtures (90).

Wurst III and Putman (2012) evaluated WMA OGFC mixtures with Evotherm WMA, foamed WMA, and conventional HMA OGFC using draindown, permeability, and abrasion resistance. Draindown testing was performed for all the mixtures in accordance with AASHTO T305 and this testing provided the rate of binder draindown relative to the binder content of the mixture. The abrasion resistance of the OGFC mixtures in this study was evaluated using the Cantabro abrasion test (92). Test results showed that fibers could be removed from OGFC mixtures when using the WMA technologies evaluated by this study. Based on the performance evaluation of the WMA OGFC mixtures, when the fibers were removed, the permeability of the mixture nearly doubled. Furthermore, the WMA mixtures without fibers met typical aged abrasion loss requirements and the foamed WMA mixtures without fibers performed similarly with respect to aged abrasion resistance to the HMA control mixtures with fibers. Oppositely, the HMA control mixtures without fibers showed lower resistance to abrasion than the WMA mixtures. The increased binder film thickness of the WMA mixtures contributed to the improved performance of the WMA mixtures compared to the HMA control mixtures without fibers (92).

THIS PAGE LEFT BLANK INTENTIONALLY

CONCLUSIONS AND RECOMMENDATIONS

CONCLUSIONS

The following conclusions can be made from this study:

- Literature shows that the mix designs procedures for WMA and HMA are similar except gathering information, asphalt binder selection, and evaluation and refinement of trial mixture. WMA mix design needs information such as WMA process, additive rates, planned production and compaction temperatures. The RAP binder should have a high-temperature grade that is less than the compaction temperature for the WMA. In addition, low-temperature grade improvement may be considered when using blending charts. For evaluation of WMA mixtures, a lower short-term aging temperature should be used. Coating, compactability, rutting, and moisture susceptibility testing at least should be conducted.
- Questionnaire survey and field survey revealed that some of the Foaming WMA projects used very high mixing (more than 300°F [149°C]) and laydown temperatures. This might affect the WMA pavement performances. It is difficult to determine the best WMA technology (Evotherm or Foaming) for New Mexico because pavement evaluated were new, covered by OGFC and visual inspection was used as evaluation tool.
- The questionnaire survey responses from both project managers and contractors from all the seven selected WMA projects concluded that:
 - The WMA tends to remain workable longer than HMA allowing for a greater compaction window and easier handling of the mixture.
 - Some WMA technologies cannot handle high RAP contents as adequate mixing of the materials becomes an issue at the lower temperatures. Other technologies allow greater RAP contents with no issues with adequate mixing. In addition, no issues with homogeneity of the blended RAP and virgin binder were found within 25% RAP.
 - There are no issues about rutting resistance and moisture damage of WMA projects and WMA laboratory tests so far.
 - Evotherm additive and Foaming process are reported that each one has its own benefits. Foaming process is the most cost effective method while Evotherm has a higher cost but also allows for lower temperatures than Foaming. Both products have performed as expected so far so the difference in performance need further investigated.
 - The WMA pavements perform as well as HMA pavements so far.
- Field survey evaluated six (three Evotherm and three Foaming) WMA projects implemented in New Mexico and concluded that all the WMA pavements have performed well so far. Overall, HMA performed slightly better than foamed WMA, which performed slightly better than Evotherm WMA. However, this result is limited by the OGFC layer that is covering WMA layer in the field.

- The evaluation of existing/new laboratory tests for common issues related to WMA volumetric property tests, rutting tests, dynamic modulus tests, fatigue tests, low temperature tests, moisture susceptibility test, workability and compactability, RAP in WMA, oxidative aging of WMA and performance of WMA OGFC reveal the following conclusions:
 - Average binder absorption of WMA is smaller than HMA. However, there should not be any reduction in asphalt content in mix design calculation to compensate this low absorption as scenarios changes in the field after serving 3 or more years.
 - For rutting test, three methods were provided (APA test, HWTD test, and FN test). Common results from these three test methods indicated that the rutting resistances of WMA mixtures are equal to or slightly lower than the HMA control mixtures, which are primarily attributed to reduced aging of WMA. APA has high variability; HWTD test and FN test are most appropriate.
 - For dynamic modulus tests, three test methods discussed are AASHTO TP 79, IDT method, and SASW method. Common test results indicated that the most dynamic moduli of WMA mixtures are smaller than the HMA control.
 - For fatigue life tests, three test methods discussed are DMA test, Beam Fatigue test, and Overlay test. Common test results indicated that the fatigue cracking resistances of most WMA mixtures are better than HMA mixtures.
 - For low temperature cracking tests, IDT test and semi-circular bending test are currently used. Results from IDT test indicate that the thermal cracking resistance of most WMA mixtures is equal to or better than the HMA control mixtures.
 - For evaluation of moisture susceptibility, TSR test is the most popular. HWTD test is the second dominant test used by state DOTs. State DOTs indicate that WMA pavement do not experienced failure or distress from moisture damage. WMA pavements are more likely to be susceptible to moisture-related damage during early life as compared to HMA pavements. However, the difference between HMA and WMA moisture damage decreases as WMA mixtures experience aging.
 - As per workability and compactability of WMA as compared to HMA, the differences are only significant at temperatures that are below typical WMA production temperatures. This indicates that it is not necessary to evaluate workability at the planned production temperature. The evaluation of coating at the planned temperature is sufficient. However, compactability of WMA should be evaluated by using the gyratory compactor to determine the gyrations to 92% relative density at the planned field compaction temperature and a second temperature that is approximately 54°F (30°C) lower than the planned field compaction temperature. A maximum increase in gyrations of 25% is recommended when compaction temperature is reduced.
 - For WMA with RAP, researchers indicate that moisture and rutting resistance can be improved through the combination of WMA and RAP. However, WMA containing RAP might have a longer fatigue life than HMA containing the same content of RAP. In

addition, the presence of RAP at low temperatures may lead to increase thermal cracking potential regardless of the WMA additive employed.

- For oxidative aging of WMA, the WMA additives not only reduce short-term aging effects on the rheological properties of asphalt binder but they also slow down the growing rate of binder stiffness over time.
- For WMA OGFC, researchers suggested that a higher RAP percentage could be used to design porous asphalt mixtures, as WMA technology would improve the high temperature mixing for mixtures containing RAP. In addition, fibers could be removed from OGFC mixtures when using the WMA technologies based on the improved performance on permeability and aged abrasion resistance.

RECOMMENDATIONS

This study is completely based on literature and field visual inspection. Field visual inspection was limited by the fact that most of the WMA pavements are covered by OGFC layer which was essentially evaluated. Also they are relatively new pavements. Therefore, long term performances of WMA need to be evaluated in the laboratory before NMDOT makes significant field investments in WMA paving, which is irreversible.

The following recommendations can be made to establish Phase 2 study:

- For WMA binder and mixtures, laboratory testing need to be conducted to understand the effects of different water injection rates, additive rates, mixing and compaction temperatures, binder and aggregate types on the properties of WMA. The laboratory testing should include at least coating, compactability, rutting resistance, and moisture susceptibility tests for mix design, basic binder testing for WMA binder and basic mechanical testing for WMA mixtures.
- For WMA pavements, field testing such as falling weight deflectometer (FWD) test should be conducted to evaluate the physical properties of pavement. Field cores also need to be gathered for further laboratory testing such as rutting test, moisture susceptibility test, modulus test, fatigue test, low temperature test, and so on.
- Other WMA technologies should be encouraged to implement in New Mexico and be tested.
- Most of the foaming technology WMA projects included in this study used temperature higher than traditional definition of 275 °F. High mixing temperature make the mix more aged, stiffer, and increased TSR value to pass. Field performances of these projects should be studied though field core testing in the laboratory as well as non-destructive testing of field pavements.

- A comprehensive study is needed to differentiate the stripping and oxidative performances between evotherm and foaming WMA technologies in New Mexico. Often, the evotherm suppliers claim that evotherm help reduce stripping because it encapsulates the lighter component of the asphalt binder and thereby help reduce oxidation and better coating and works as an anti-stripping agent.
- It was evident from the field visuals inspections in this study, reflective cracking are severe on the shoulder and edge of the pavements. Because shoulders oxidized more than lane because of UV radiation, heat, and no kneading action by traffic. In the past, shoulders would have contained 0.5% more binder than the paving lane to have high film thickness. In this regard future research can determine the film thickness of evotherm and foaming technology by taking cores from six projects surveyed.
- As RAP is used in WMA and OGFC can be made out of WMA, some laboratory testing such as dynamic modulus, creep, drain-down tests can be performed to separate benefits of using evotherm from foaming technology. Of course, field FWD and GPR testing are always encouraged.

REFERENCES

1. NAPA (National Asphalt Pavement Association). Warm-Mix Asphalt. http://www.asphalt pavement.org/index.php?option=com_content&view=article&id=148&Itemid=329. Accessed Sep. 23, 2013.
2. D'Angelo, J., E. Harm, J. Bartoszek, G. Baumgardner, M. Corrigan, J. Cowser, T. Harman, M. Jamshidi, W. Jones, D. Newcomb, B. Prowell, R. Sines, and B. Yeaton. Warm-Mix Asphalt: European Practice. *Report No. FHWA-PL-08-007*, American Trade Initiatives, Alexandria, USA, 2008.
3. Kristjansdottir, O., S. T. Muench, Michael, L. and G. Burke. Assessing Potential for Warm-Mix Asphalt Technology Adoption. In *Transportation Research Record: Journal of the Transportation Research Board; No. 2040*, TRB, National Research Council, Washington, D.C., 2007, pp. 91–99.
4. Shehata, M., M. S. Ahmed, and M. Ibrahim. Warm Mix Asphalt Performance, Potential Benefits and Other Parameters. Civil Engineering Department, Ryerson University, Ontario, Canada.
5. Bonaquist, R. Mix Design Practices for Warm Mix Asphalt.” *National Cooperative Highway Research Program (NCHRP) Report 691*, Transportation Research Board, Washington, D.C., 2011.
6. Rubio, M. C., G. Martinez, L. Baena, and F. Moreno. Warm mix asphalt: an overview. *Journal of Cleaner Production*, Vol. 24, 2012, pp. 76-84.
7. Dtu, J. J. Warm Mix Asphalt Investigation. *Master of Science Thesis*, Riga Technical University, Kgs. Lyngby, Denmark, 2010.
8. Bueche, N. *Warm Asphalt Bituminous Mixtures with Regards to Energy, Emissions and Performance Young Researchers Seminar (YRS) LAVOC-CONF-2010-002*, Torino, Italy, 2009.
9. European Asphalt Pavement Association. The Use of Warm Mix Asphalt. *EAPA position paper -- January 2010*, <http://www.eapa.org/>. Accessed Jun. 24, 2013.
10. Zaumanis, M. Warm mix asphalt Investigation. *PhD Thesis*, Riga Technical University, Kgs. Lyngby, Denmark, 2010.
11. Chemical Plus. Fischer-Tropsch Wax. <http://www.chemicalplus.com>. Accessed Jun. 24, 2013.

12. Logaraj, S., and A. Almeida Surface-active Bitumen Additive for Warm Mix Asphalt with Adhesion Promoting Properties. *Akzo Nobel, Surface Chemistry LLC*, <http://www.akzonobel.com/>. Accessed Jun. 24, 2013.
13. Hurley, G.C., and B.D. Prowell. Evaluation of Sasobit® for Use in Warm Mix Asphalt. *National Center for Asphalt Technology. Report 05-06*, Auburn University, Auburn, USA, 2005.
14. Vaitkus, A., A. Cygas, A. Laurinavicius, and Z. Perveneckas. Analysis and evaluation of possibilities for the use of warm mix asphalt in Lithuania. *The Baltic Journal of Road and Bridge Engineering*, Vol. 4, No. 2, 2009, pp. 80-86.
15. Vaitkus, A., V. Vorobjovas, and L. Ziliut. The Research on the Use of Warm Mix Asphalt for Asphalt Pavement Structures. In *XXVII International Baltic Road conference. Riga, Latvia*, 2009.
16. Shang, L., S. Wang, Y. Zhang, and Y. Zhang. Pyrolyzed wax from recycled cross-linked polyethylene as warm mix asphalt (WMA) additive for SBS modified asphalt. *Construction and Building Materials*, Vol. 25, No. 2, 2011, pp. 886-891.
17. Larsen, O.R. Warm Asphalt Mix with Foam – WAM Foam. *IRF 2001 Partie B: Thèmes Techniques*, S.00469. Kolo Veidekke, Norway, 2001.
18. Muthen, K. M. Foamed asphalt mixes-Mix design procedure. *Transportation Research Record*, 898, 290-296. In *Transportation Research Record.: Journal of the Transportation Research Board; No. 898*, TRB, National Research Council, Washington, D.C., 1998, pp. 290–296.
19. Butz, T., I. Rahimian, and G. Hildebrand. Modification of road bitumen with the Fischer-Tropsch paraffin Sasobit. *Journal of Applied Asphalt Binder Technology*, Vol. 1, No. 2, 2001, pp. 70-86.
20. Smith, A. Advera WMA Zeolite. *WMA Technical Working Group. PQ Corporation Presentation*, Hunt Valley, USA, 2007.
21. Chowdhury, A., and J.W. Button. A Review of Warm Mix Asphalt. *Texas Transportation Institute e Technical Report 473700-00080-1*, College Station, USA, 2008.
22. Hamzah, M.O., A. Jamshidi, and Z. Shahadan. Evaluation of the Potential of Sasobit to Reduce Required Heat Energy and CO2 Emission in the Asphalt Industry. *Journal of Cleaner Production*, Vol. 18, No. 18, 2010, pp. 1859-1865.
23. Von Devivere, M., W Barthel, and J.P. Marchand. Warm Asphalt Mixes by Adding Aspha-Min®, a Synthetic Zeolite. Eurovia GmbH, 2011, <http://www.aspha-min.com/>. Accessed Jun. 24, 2013.

24. Advanced Asphalt Technologies, LLC., et al. Special mixture design considerations and methods for warm mix asphalt: a supplement to NCHRP report 673, A manual for design of hot mix asphalt with commentary. *National Cooperative Highway Research Program (NCHRP) Report 714*, Transportation Research Board, Washington, D.C., 2012.
25. Thompson, G. Warm Mix Asphalt. *Presentation at the 2012 Northwest Transportation Conference*, Corvallis, Oregon, February 8, 2012.
26. Anderson, R. M., G. Baumgardner, R. May, and G. Reinke. Engineering properties, emissions, and field performance of warm mix asphalt technologies. *National Cooperative Highway Research Program (NCHRP) Interim Report 9-47*, Transportation Research Board, Washington, D.C., 2008.
27. Witczak, M.W., K. Kaloush, T. Pellinen, M. El-Basyouny, and H. Von Quintus. Simple Performance Test for Superpave Mix Design. *National Cooperative Highway Research Program (NCHRP) Report 465*, Transportation Research Board, Washington, D.C., 2002.
28. Su, K., R. Maekawa, and Y. Hachiya. Laboratory evaluation of WMA mixture for use in airport pavement rehabilitation. *Construction and Building Materials*, Vol. 23, No. 7, 2009, pp. 2709-2714.
29. Barthel, W., J. P. Marchand, and M. e. Von Deviver. Warm Asphalt Mixes by Adding a Synthetic Zeolite. Eurovia GmbH, 2005.
30. Larsen, O. R., Ø. Moen, C. Robertus, and B. G. Koenders. WAM-Foam Asphalt Production at Lower Operating Temperatures as an Environmental Friendly Alternative to HMA. *Presented at Third Eurasphalt and Eurobitume Congress*, Vienna, Austria, 2004.
31. De Groot, P. C., C. Bowen, B. G. Koenders, D. A. Stoker, O. Larsen, and J. Johansen, A Comparison of Emissions from Hot Mixture and Warm Asphalt Mixture Production. *Presented at International Road Federation World Meeting*, Paris, 2001.
32. Kristjansdottir O. Warm Mix Asphalt for Cold Weather Paving. *PhD Thesis*, University of Washington, Seattle, USA, 2006.
33. Xiao, F., P.E.W. Zhao, and S.N. Amirkhanian. Fatigue behavior of rubberized asphalt concrete mixtures containing warm asphalt mixtures. *Construction and Building Materials*, Vol. 23, No. 10, 2009, pp. 3144-3151.
34. Al-Rawashdeh, A.S. Performance Assessment of Warm Mix Asphalt (WMA) Pavements. *PhD Thesis*, Rus College of Engineering and Technology, Ohio University, Athens, USA, 2008.

35. Contractor chooses warm-mix asphalt for road project requiring rigorous, high standards. The Performance Factor. Hot-mix Magazine. http://www.hotmixmag.com/index.php?option=com_content&view=article&id=294:the-performance-factor&catid=55:vol-16-num-2-2011. Accessed Sep. 24, 2013.
36. You, Z., S.W. Goh, and T.J. Van Dam. Laboratory Evaluation and Pavement Design for Warm Mix Asphalt. *Proceedings of the 2007 Mid-Continent Transportation Research Symposium*, Ames, USA, 2007.
37. Brown, D.C. Warm Mix: the lights are green. *Hot Mix Asphalt Technology-January/February* 2008, pp. 20-32.
38. Corrigan, M. Warm Mix Asphalt Update. *Work Mix Seminar and Demonstration*, Baton Rouge, USA, 2009.
39. Diefenderfer, S., and A. Hearon. Laboratory Evaluation of a Warm Asphalt Technology for Use in Virginia. *Virginia department of transportation – Federal Highway Administration NO. FHWA/VTRC 09-R11*, Charlottesville, USA, 2008.
40. Hurley, G.C., and B.D. Prowell. Evaluation of Aspha-Min® Zeolite for Use in Warm Mix Asphalt. *National Center for Asphalt Technology, Report 05-04*, Auburn University, Auburn, USA, 2005.
41. Hurley, G.C., and B.D. Prowell. Evaluation of Evotherm® for Use in Warm Mix Asphalt. *National Center for Asphalt Technology, Report 06-02*, Auburn University, Auburn, USA, 2006.
42. Bower, N., Wen, H., K. Willoughby, J. Weston, and J. DeVol. Evaluation of the Performance of Warm Mix Asphalt in Washington State. *Report No. WA-RD 789.1*, Washington State University, Pullman, USA, 2012.
43. Hurley, G. C., and B. D. Prowell. Evaluation of Potential Processes for Use in Warm Mix Asphalt. *Journal of the Association of Asphalt Paving Technologists*, Vol. 75, 2006, pp. 41-90.
44. Button, J. W., C. Estakhri, and A. Wimsatt. A Synthesis of Warm Mix Asphalt. *Texas Transportation Institute, Report No. FHWA/TX-07/0-5597-1*, The Texas A&M University System, College Station, USA, 2007.
45. Tao, M. and R. B. Mallick. Evaluation of the Effects of Warm Mix Asphalt Additives on Workability and Mechanical Properties of Reclaimed Asphalt Pavement (RAP) Material. In *Transportation Research Record: Journal of the Transportation Research*

- Board; No. 2126*, TRB, National Research Council, Washington, D.C., 2009, pp. 151-160.
46. Jones, C., R. West, G. Julian, A. Taylor, A. Kvasnak, and Hurley, G. Evaluation of Warm Mix Asphalt in Walla Walla, Washington. *National Center for Asphalt Technology, Report 11-06*, Auburn University, Auburn, USA, 2011.
 47. Hurley, G. C., B. D. Prowell, and A. N. Kvasnak. Michigan field trial of warm mix asphalt technologies: construction summary. *National Center for Asphalt Technology, Report No. 09-10X*, Auburn University, Auburn, USA. 2009.
 48. Aschenbrener, T., B. Schiebel, and R. West. Three-Year Evaluation of the Colorado Department of Transportation's Warm Mix Asphalt Experimental Feature on I-70 at Silverthorne, Colorado. *NCAT Report 11-02*, National Center for Asphalt Technology, Auburn, AL, 2011.
 49. Kim, Y. R., J. Zhang, and H. Ban. Implementation of Warm-Mix Asphalt Mixtures in Nebraska Pavements. *University of Nebraska-Lincoln Report No. MPM-02*, Lincoln, USA, 2010.
 50. Estakhri, C., J. Button, and A. E. Alvarez. Field and Laboratory Investigation of Warm Mix Asphalt in Texas. *Report No. FHWA/TX-10/0-5597-2*, Texas Transportation Institute, The Texas A&M University System, College Station, TX, 2010.
 51. Astec Industries, Inc. Double Barrel Green. *Product Home Page*. http://www.astecinc.com/index.php?option=com_content&view=article&id=117&Itemid=188. Accessed Sep. 29, 2013.
 52. MAXAM Equipment, Inc. AQUABlack WMA. *Product Home Page*. <http://maxamequipment.com/AQUABlackWMA.htm>. Accessed Sep. 29, 2013.
 53. Terex Corporation. Warm Mix Asphalt System. *Product Home Page*. <http://www.terex.com/roadbuilding/en/products/new-equipment/asphalt-plants/warm-mix-asphalt/index.htm>. Accessed Sep. 29, 2013.
 54. Gierhart, D. Warm Mix Asphalt: What is it and how can we benefit? *Presentation at the SE States Pavement Association Management and Design Conference Southeast Pavement Preservation Partnership Meeting*, 2009.
 55. MeadWestvaco Corporation. Evotherm Warm Mix Asphalt. *Product Home Page*. <http://www.meadwestvaco.com/SpecialtyChemicals/AsphaltAdditives/MWV002106>. Accessed Sep. 29, 2013.
 56. Jones, D., R. Wu, B. W. Tsai, Q. Lu, and J. T. Harvey. Warm-Mix Asphalt Study: Test Track Construction and First-Level Analysis of Phase 1 HVS and Laboratory Testing.

Report No. UCPRC-SR-2008-11, University of California Pavement Research Center, California, USA, 2008.

57. Evotherm Warm Mix Asphalt Technology. What is Evotherm Warm Mix Asphalt Technology.
<https://www.dot.ny.gov/divisions/engineering/technical-services/technical-services-repository/details/Evotherm.pdf>. Accessed Sep. 29, 2013.
58. Gierhart, D. Warm Mix Asphalt: What is it and how can we benefit? *Presentation at the 2011 Louisiana Transportation Conference*, Baton Rouge, Louisiana, January 11, 2011.
59. NMDOT. New Mexico Department of Transportation Supplemental Specifications for Warm Mix Asphalt. NMDOT, Section 424, 2014.
60. Bandini, P., S. B. Halter, K. R. Montoya, H. V. Pham, and G. C. Migliaccio. *Improving NMDOT's Pavement Distress Survey Methodology and Developing Correlations between FHWA's HPMS Distress Data and PMS Data*. Publication NM10MNT-01. NMDOT Research Bureau, Albuquerque, NM, 2012.
61. FHWA. *Smoothness*. <http://www.fhwa.dot.gov/pavement/smoothness/>. Accessed Jul. 30, 2014.
62. *Highway Functional Classification Concepts, Criteria and Procedures*. FHWA, U.S. Department of Transportation, 2013.
63. National Center for Asphalt Technology (NCAT). NCHRP 9-47A Offers Recommendations for WMA Mix Design Changes. *Asphalt Technology E-News*, Vol. 25, No. 1, 2013.
64. Hurley, G. C., B. D. Prowell, and A. N. Kvasnak. Missouri Field Trial of Warm Mix Asphalt Technologies: Construction Summary. *NCAT Report No. 10-02*, National Center for Asphalt Technology, Auburn, AL, 2010.
65. Hurley, G. C., B. D. Prowell, and A. N. Kvasnak. Ohio Field Trial of Warm Mix Asphalt Technologies: Construction Summary. *NCAT Report No. 09-04*, National Center for Asphalt Technology, Auburn, AL, 2009.
66. Hurley, G. C., B. D. Prowell, and A. N. Kvasnak. Wisconsin Field Trial of Warm Mix Asphalt Technologies: Construction Summary. *NCAT Report No. 10-04*, National Center for Asphalt Technology, Auburn, AL, 2010.
67. Guidelines for Project Selection and Materials Sampling, Conditioning, and Testing in WMA Research Studies. *Research Results Digest 370*, Transportation Research Board, 2012.

68. Liu, J. Evaluation of Warm Mix Asphalt for Alaska Conditions. *Report No. INE/AUTC 11.09*, 2010.
69. Prowell, B., G. Hurley, A. de Fortier Smit, and J. Kim. Alabama Warm Mix Asphalt Field Study: Final Report. *NCAT Report No. Report 10-XX*, National Center for Asphalt Technology, Auburn, AL, 2010.
70. You, Z., S. W. Goh, and Q. Dai. Laboratory Evaluation of Warm Mix Asphalt. *Project NO. RC-1556*, Michigan Technological University, Houghton, MI, 2011.
71. Sholar, G. A., T. M. Nash, J. A. Musselman, and P. B. Upshaw. FDOT's Experience with Warm Mix Asphalt. *Report No. FL/DOT/SMO/09-527*, Florida Department of Transportation, FL, 2009.
72. Lai, J. S., Y. J. Tsai, and Z. Wang. Evaluating Constructability and Properties of Warm Mix Asphalt: Final Report. *Report No. FHWA-GA-10-0904*, Georgia Institute of Technology, Atlanta, GA, 2010.
73. Arega, Z, and A. Bhasin. Final Report: Binder Rheology and Performance in Warm Mix Asphalt. *Report No. FHWA/TX-12/0-6591-1*, Center for Transportation Research, The University of Texas at Austin, Austin, TX, 2012.
74. Asphalt Mixture Performance Tester (AMPT). *FHWA-HIF-13-005*, U.S. Department of Transportation Federal Highway Administration, 2013.
75. Buss, A., and R. C. Williams. Investigation of Warm-Mix Asphalt for Iowa Roadways-Phase II: Final Report. *Report No. IHRB Project TR-635*, Institute for Transportation, Iowa State University, Ames, IA, 2013.
76. Shiwakoti, H. Development of A Rapid Test To Determine Moisture Sensitivity of HMA (Superpave) Mixtures. *Thesis*, University of Kansas, Lawrence, KS, 2007.
77. Sousa, P., E. Kassem, E. Masad, and D. Little. New design method of fine aggregates mixtures and automated method for analysis of dynamic mechanical characterization data. *Construction and Building Materials Vol. 41*, 2013, pp. 216-223.
78. Overlay Test. *TxDOT Designation: TEX-248-F*, 2014.
79. Li, X-J., and M. O. Marasteanu. Using semicircular bending test to evaluate low temperature fracture resistance for asphalt concrete. *Experimental mechanics Vol. 50 (7)*, 2010, pp. 867-876.
80. Martin, A. E., E. Arambula, F. Yin, L. G. Gucalon, A. Chowdhury, R. Lytton, J. Epps, C. Estakhri, and E. S. Park. Evaluation of the Moisture Susceptibility of WMA Technologies. *National Cooperative Highway Research Program (NCHRP) Report 763*, Transportation Research Board, Washington, D.C., 2014.

81. Bennert, T., G. Reinke, W. Mogawer, and K. Mooney. Assessment of workability and compactability of warm-mix asphalt. In *Transportation Research Record: Journal of the Transportation Research Board*, No. 2180, TRB, National Research Council, Washington, D.C., 2010, pp. 36-47.
82. Reinke, G. Information Related to Warm Mix Binder Rheology. MTE Technical Communication Document. Mathy Technology Engineering Services, Inc., Onalaska, Wisc., 2009.
83. Prowell, B., and G. C. Hurley. Warm-mix asphalt: Best practices. Quality Improvement Series 125, National Asphalt Pavement Association, Lanham, MD., 2007.
84. Hill, B., B. Behnia, W. G. Buttlar, and H. Reis. Evaluation of warm mix asphalt mixtures containing reclaimed asphalt pavement through mechanical performance tests and an acoustic emission approach. *Journal of Materials in Civil Engineering*, Vol 25, No. 12, 2012, pp. 1887-1897.
85. Doyle, J. D., M. Mejias-Santiago, E. R. Brown, and I. L. Howard. Performance of high RAP-WMA surface mixtures. *Journal of the Association of Asphalt Paving Technologists*, No. 80, 2011, pp. 419-458.
86. Zhao, S., B. Huang, X. Shu, X. Jia, and M. Woods. Laboratory performance evaluation of warm-mix asphalt containing high percentages of reclaimed asphalt pavement. In *Transportation Research Record: Journal of the Transportation Research Board*, No. 2294, 2012, pp. 98-105.
87. Gandhi, T. and S. Amirkhania. *Laboratory Simulation of Warm Mix Asphalt (WMA) Binder Aging Characteristics. Airfield and Highway Pavements*, 2008, pp. 195-204.
88. Banerjee, A., A. F. Smit, and J. A. Prozzi. The effect of long-term aging on the rheology of warm mix asphalt binders. *Fuel*, Vol. 97, 2012, pp. 603-611.
89. Glover, C. J., R. Han, X. Jin, N. Prapaitrakul, Y. Cui, A. Rose, J. J. Lawrence et al. Evaluation of Binder Aging and Its Influence in Aging of Hot Mix Asphalt Concrete: Technical Report. *Report No. FHWA/TX-14/0-6009-2*, Texas A&M Transportation Institute, College Station, TX, 2014.
90. Goh, S. W., and Z. You. Mechanical properties of porous asphalt pavement materials with warm mix asphalt and RAP. *Journal of Transportation Engineering*, Vol. 138, No. 1, 2011, pp. 90-97.

91. Mahmoud, A. F. F., and H. Bahia. Using the gyratory compactor to measure mechanical stability of asphalt mixtures. *Report NO. WHRP 05-02*, University of Wisconsin, Madison, Madison, Wisconsin, 2004.
92. Wurst III, J. E., and B. J. Putman. Laboratory evaluation of warm-mix open graded friction course mixtures. *Journal of Materials in Civil Engineering*, Vol. 25, No. 3, 2012, pp. 403-410.

THIS PAGE LEFT BLANK INTENTIONALLY

APPENDIX A

SURVEY OF SEVEN WMA PROJECTS IN NM

The survey questions are presented in this appendix.

The survey questionnaire is designed to be completed by the New Mexico's Paving Contractor, Mixing Plants, Asphalt Engineers, Mix Designers and NMDOT Districts:

Name of the Person:	
Agency/Company:	
Job Title:	
Email:	
Phone	

Question 1. What's your field experience on the construction of Warm Mix Asphalt (WMA) pavement?

Number of years of experience		
How many mixes		
How many projects	With chemical additives (Evotherm)	
	With Foaming processes	

Question 2. This question is about WMA project descriptions. Please tick the project you participated.

Six Project	District	Project Number	Highway	Beg MP	Ending MP	WMA Technology	Company	RAP Percent	Tick (✓)
1	2	2100200	NM 48	0.000	3.356	Foaming	MAXAM Equipment	25%	
2	3	A300370	I-25	229.249	232	Evotherm	MeadWestvaco	25%	
3	4	4100670	I-40	355.0	359.5	Foaming	Terex	0%	
4	6	CN 6100430	NM 264	10.6	13.1	Evotherm	MeadWestvaco	0%	
5	6	6100510	NM 118	24.5	27.0	Evotherm	MeadWestvaco	0%	
6	6	6100450	US 60	73	76	Foaming	Astec	0%	
7	6	6100451	US 60	69	73	Evotherm	MeadWestvaco	0%	

(a). What is the pavement type: conventional flexible pavement, full-depth asphalt pavement, or composition pavement (both WMA and PCC)?

(b). What is the project for (pavement rehabilitation or new road construction)?

(c). Is the WMA only the surface course? What is the thickness of the WMA layer?

(d). How about the traffic conditions (load spectra and volume)?

(e). Did the traffic design satisfy the actual traffic demand? Any overloading or any other concerns?

(f). How about the environmental conditions (precipitation data, ambient temperature data, subsurface moisture conditions, and subsurface temperature conditions)?

(g) Could you explain more about the WMA project location, urban area or not, and how about the population around the pavement?

(h). What are the differences between WMA and HMA mix design, do you think?

(i) Are there some advantages or disadvantages of combining RAP and WMA, comparing with RAP and HMA (such as the amount of RAP used, any effects)?

(j). What are the differences between WMA and HMA pavement construction (such as pavement compactability, environmental benefits, length of construction season, haul distance, times of road construction and opening)?

(k). Have you ever seen any surface and subsurface drainage problems in WMA pavements? (For example, pavement does not dry soon after rainfall.)?

(l). What are the differences of QA/QC data between WMA and HMA projects, do you think? What is differently done about the QA/QC of WMA project?

(m). Any other concerns or remarks about the WMA projects?

Question 3. This question is about concerns with WMA.

(a). The biggest concern about WMA is the amount of water left on the aggregate due to lower processing temperature. Does asphalt binder trap water as it coats the aggregate?

1). What moisture damage test (in the lab) did you do during the mix design stage?

2) What long-term effects (in the field) do you anticipate?

(b). Rutting resistance may be a concern for certain WMA technologies. The lower mixing and compaction temperatures for WMA cause the binder in WMA to age less than the binder in HMA, which indicates that WMA binder may be less stiff than HMA binder. Dose WMA have rutting problems after paving?

1). What rutting resistance test (in the lab) did you do during the mix design stage?

2) What long-term effects (in the field) do you anticipate?

(c). High contents of RAP can be incorporated into WMA due to the reduced aging of virgin asphalt. However, more than 20% RAP in a mix needs further binder testing to determine the PG of the blended binder. Have you ever done further tests to redetermine the PG of blended binder when the content of RAP is high? What tests did you do and how did the PG grade change?

(d). Variability of RAP and the degree of blending between virgin binder also affect the performance of mix, especially at lowered mixing temperature. RAP needs lower temperature to be mixed. For your experience, was the low temperature good for the blended WMA binder? How was the homogeneity of the blended binder with RAP and virgin WMA?

(e). For the plant concern with WMA, low baghouse temperature of WMA can cause condensation. Have ever seen some problems with the baghouse?

(f). The WMA technologies used in New Mexico are mainly Evotherm and Foaming. How do you feel about these two technologies? Which technology do you think better (such as cost and performance)?

(g) For some WMA projects, we found oxidation of the pavement is faster than the traditional HMA pavement (WMA may be totally oxidized after one year and a half). Have you ever confronted this situation? What reasons do you think cause this phenomenon?

(h) Any other concerns with WMA technologies (such as incomplete coating of aggregate, additional expense, and one more material/process to control)?

Question 4. This question is about WMA pavements' performance in New Mexico.

(a). How are the pavements with WMA performing of your projects, any distress (cracking, deformation, deterioration and mat problems)?

(b). Why do the pavements (in your answer (a) above) perform (good or bad) as they do, what do you think caused the pavement distress (mix design, construction, materials, climate, traffic, structural design and geometric design)?

(c). What do you think about WMA vs. HMA (serviceability and durability)?

Question 5. What improvements can be made to the NMDOT's specification for WMA?

APPENDIX B

SURVEY RESPONSES

The survey responses are presented in this appendix.

Name of the Person:	Jerry Hickman
Agency/Company:	NMDOT
Job Title:	Project Manager
Email:	Jerry.hickman@state.nm.us
Phone	575-585-2090

Question 1. What's your field experience on the construction of Warm Mix Asphalt (WMA) pavement?

Number of years of experience	1	
How many mixes	1	
How many projects	With chemical additives (Evotherm)	0
	With Foaming processes	1

Question 2. This question is about WMA project descriptions. Please tick the project you participated.

Six Project	District	Project Number	Highway	Beg MP	Ending MP	WMA Technology	Company	RAP Percent	Tick (√)
1	2	2100200	NM 48	0.000	3.356	Foaming	MAXAM Equipment	25%	X
2	3	A300370	I-25	229.249	232	Evotherm	MeadWestvaco	25%	
3	4	4100670	I-40	355.0	359.5	Foaming	Terex	0%	
4	6	CN 6100430	NM 264	10.6	13.1	Evotherm	MeadWestvaco	0%	
5	6	6100510	NM 118	24.5	27.0	Evotherm	MeadWestvaco	0%	
6	6	6100450	US 60	73	76	Foaming	Astec	0%	

(a). What is the pavement type: conventional flexible pavement, full-depth asphalt pavement, or composition pavement (both WMA and PCC)?

Conventional Pavement 2" Mill and Fill

(b). What is the project for (pavement rehabilitation or new road construction)?

Pavement rehabilitation

(c). Is the WMA only the surface course? What is the thickness of the WMA layer?

Yes and 2"

(d). How about the traffic conditions (load spectra and volume)?

AADT (2011) INTERIM	15,225
AADT (2022)	17,077
AADT (2032) DESIGN	18,762
DHV (2012)	1,693
DHV (2022)	1,878
DHV (2032)	2,064
%HEAVY COMMERCIAL (2011)	14.00%
%HEAVY COMMERCIAL (2032-DESIGN)	13.78%
%HEAVY COMMERCIAL (DURING DHV)	11.78%
ESAL (20)	3,147,272

(e). Did the traffic design satisfy the actual traffic demand? Any overloading or any other concerns?

Yes. No concerns

(f). How about the environmental conditions (precipitation data, ambient temperature data, subsurface moisture conditions, and subsurface temperature conditions)?

Temperature Range: From 48f (January) to 82f (June) Average high of 65.5f, Average low of 32.9f
Precipitation: 22.7"

(g) Could you explain more about the WMA project location, urban area or not, and how about the population around the pavement?

Urban area (Population of 8,000)

(h). What are the differences between WMA and HMA mix design, do you think?

WMA allows for easier handling

(i) Are there some advantages or disadvantages of combining RAP and WMA, comparing with RAP and HMA (such as the amount of RAP used, any effects)?

(j). What are the differences between WMA and HMA pavement construction (such as pavement compactability, environmental benefits, length of construction season, haul distance, times of road construction and opening)?

There will be some environmental benefits and cost saving in fuel for contractors

(k). Have you ever seen any surface and subsurface drainage problems in WMA pavements? (For example, pavement does not dry soon after rainfall.)?

NO

(l). What are the differences of QA/QC data between WMA and HMA projects, do you think? What is differently done about the QA/QC of WMA project?

The material was tested exactly the same and evaluated the same

(m). Any other concerns about the WMA projects?

NO

Question 3. This question is about concerns with WMA.

(a). The biggest concern about WMA is the amount of water left on the aggregate due to lower processing temperature. Does asphalt binder trap water as it coats the aggregate?

1). What moisture damage test (in the lab) did you do during the mix design stage?

N/A

2) What long-term effects (in the field) do you anticipate?

N/A

(b). Rutting resistance may be a concern for certain WMA technologies. The lower mixing and compaction temperatures for WMA cause the binder in WMA to age less than the binder in HMA, which indicates that WMA binder may be less stiff than HMA binder. Dose WMA have rutting problems after paving?

Not to date

1). What rutting resistance test (in the lab) did you do during the mix design stage?

N/A

2) What long-term effects (in the field) do you anticipate?

None

(c). High contents of RAP can be incorporated into WMA due to the reduced aging of virgin asphalt. However, more than 20% RAP in a mix needs further binder testing to determine the PG of the blended binder. Have you ever done further tests to redetermine the PG of blended binder when the content of RAP is high? What tests did you do and how did the PG grade change?

N/A

(d). Variability of RAP and the degree of blending between virgin binder also affect the performance of mix, especially at lowered mixing temperature. RAP needs lower temperature to be mixed. For your experience, was the low temperature good for the blended WMA binder? How was the homogeneity of the blended binder with RAP and virgin WMA?

N/A

(e). For the plant concern with WMA, low baghouse temperature of WMA can cause condensation. Have ever seen some problems with the baghouse?

N/A

(f). The WMA technologies used in New Mexico are mainly Evotherm and Foaming. How do you feel about these two technologies? Which technology do you think better (such as cost and performance)?

N/A

(g) Any other concerns with WMA technologies (such as incomplete coating of aggregate, additional expense, and one more material/process to control)?

N/A

Question 4. This question is about WMA pavements' performance in New Mexico.

(a). How are the pavements with WMA performing of your projects, any distress (cracking, deformation, deterioration and mat problems)?

This project is performing well at this point

(b). Why do the pavements (in your answer (a) above) perform (good or bad) as they do, what do you think caused the pavement distress (mix design, construction, materials, climate, traffic, structural design and geometric design)?

(c). What do you think about WMA vs. HMA (serviceability and durability)?

Do not have enough data to answer at this time

Question 5. What improvements can be made to the NMDOT's specification for WMA?

Name of the Person:	Ken Murphy
Agency/Company:	NMDOT District 3
Job Title:	District Construction Engineer
Email:	<u>Kenneth.murphy@state.nm.us</u>
Phone	505-798-6600

Question 1. What's your field experience on the construction of Warm Mix Asphalt (WMA) pavement?

Number of years of experience	2	
How many mixes	3	
How many projects	With chemical additives (Evotherm)	
	With Foaming processes	

Question 2. This question is about WMA project descriptions. Please tick the project you participated.

Six Project	District	Project Number	Highway	Beg MP	Ending MP	WMA Technology	Company	RAP Percent	Tick (√)
1	2	2100200	NM 48	0.000	3.356	Foaming	MAXAM Equipment	25%	
2	3	A300370	I-25	229.249	232	Evotherm	MeadWestvaco	25%	X
3	4	4100670	I-40	355.0	359.5	Foaming	Terex	0%	
4	6	CN 6100430	NM 264	10.6	13.1	Evotherm	MeadWestvaco	0%	
5	6	6100510	NM 118	24.5	27.0	Evotherm	MeadWestvaco	0%	
6	6	6100450	US 60	73	76	Foaming	Astec	0%	

(a). What is the pavement type: conventional flexible pavement, full-depth asphalt pavement, or composition pavement (both WMA and PCC)?

Conventional flex

(b). What is the project for (pavement rehabilitation or new road construction)?

Pave pres

(c). Is the WMA only the surface course? What is the thickness of the WMA layer?

OGFC on top of 3" WMA

(d). How about the traffic conditions (load spectra and volume)?

About 10000000 ESAL for 20 yr

(e). Did the traffic design satisfy the actual traffic demand? Any overloading or any other concerns?

Not designed

(f). How about the environmental conditions (precipitation data, ambient temperature data, subsurface moisture conditions, and subsurface temperature conditions)?

No extreme environmental factors

(g) Could you explain more about the WMA project location, urban area or not, and how about the population around the pavement?

Urban interstate

(h). What are the differences between WMA and HMA mix design, do you think?

Temperature for molding and mixing and additive

(i) Are there some advantages or disadvantages of combining RAP and WMA, comparing with RAP and HMA (such as the amount of RAP used, any effects)?

Not sure but concerned with proper RAP mixing at lower WMA temperatures

(j). What are the differences between WMA and HMA pavement construction (such as pavement compactability, environmental benefits, length of construction season, haul distance, times of road construction and opening)?

Compaction seemed easier; not sure on others

(k). Have you ever seen any surface and subsurface drainage problems in WMA pavements? (For example, pavement does not dry soon after rainfall.)?

N/A

(l). What are the differences of QA/QC data between WMA and HMA projects, do you think? What is differently done about the QA/QC of WMA project?

Administered the same

(m). Any other concerns about the WMA projects?

None at this time

Question 3. This question is about concerns with WMA.

(a). The biggest concern about WMA is the amount of water left on the aggregate due to lower processing temperature. Does asphalt binder trap water as it coats the aggregate?

Not sure

1). What moisture damage test (in the lab) did you do during the mix design stage?

Tensile strength ratio

2) What long-term effects (in the field) do you anticipate?

Not sure

(b). Rutting resistance may be a concern for certain WMA technologies. The lower mixing and compaction temperatures for WMA cause the binder in WMA to age less than the binder in HMA, which indicates that WMA binder may be less stiff than HMA binder. Dose WMA have rutting problems after paving?

1). What rutting resistance test (in the lab) did you do during the mix design stage?

None

2) What long-term effects (in the field) do you anticipate?

Not sure

(c). High contents of RAP can be incorporated into WMA due to the reduced aging of virgin asphalt. However, more than 20% RAP in a mix needs further binder testing to determine the PG of the blended binder. Have you ever done further tests to redetermine the PG of blended binder when the content of RAP is high? What tests did you do and how did the PG grade change?

(d). Variability of RAP and the degree of blending between virgin binder also affect the performance of mix, especially at lowered mixing temperature. RAP needs lower temperature to be mixed. For your experience, was the low temperature good for the blended WMA binder? How was the homogeneity of the blended binder with RAP and virgin WMA?

(e). For the plant concern with WMA, low baghouse temperature of WMA can cause condensation. Have ever seen some problems with the baghouse?

(f). The WMA technologies used in New Mexico are mainly Evotherm and Foaming. How do you feel about these two technologies? Which technology do you think better (such as cost and performance)?

(g) Any other concerns with WMA technologies (such as incomplete coating of aggregate, additional expense, and one more material/process to control)?

Question 4. This question is about WMA pavements' performance in New Mexico.

(a). How are the pavements with WMA performing of your projects, any distress (cracking, deformation, deterioration and mat problems)?

Performing well so far

(b). Why do the pavements (in your answer (a) above) perform (good or bad) as they do, what do you think caused the pavement distress (mix design, construction, materials, climate, traffic, structural design and geometric design)?

Traffic and materials (concern with RAP)

(c). What do you think about WMA vs. HMA (serviceability and durability)?

Not sure yet

Question 5. What improvements can be made to the NMDOT's specification for WMA?

Name of the Person:	Shawn Hammer
Agency/Company:	Fisher Sand & Gravel-NM, Inc.
Job Title:	Quality Control Manager
Email:	<u>shammer@fisherind.com</u>
Phone	(505) 867-2600

Question 1. What's your field experience on the construction of Warm Mix Asphalt (WMA) pavement?

Number of years of experience	3	
How many mixes	5	
How many projects	With chemical additives (Evotherm)	2
	With Foaming processes	3

Question 2. This question is about WMA project descriptions. Please tick the project you participated.

Six Project	District	Project Number	Highway	Beg MP	Ending MP	WMA Technology	Company	RAP Percent	Tick (√)
1	2	2100200	NM 48	0.000	3.356	Foaming	MAXAM Equipment	25%	
2	3	A300370	I-25	229.249	232	Evotherm	MeadWestvaco	25%	x
3	4	4100670	I-40	355.0	359.5	Foaming	Terex	0%	x
4	6	CN 6100430	NM 264	10.6	13.1	Evotherm	MeadWestvaco	0%	
5	6	6100510	NM 118	24.5	27.0	Evotherm	MeadWestvaco	0%	
6	6	6100450	US 60	73	76		Astec	0%	

(a). What is the pavement type: conventional flexible pavement, full-depth asphalt pavement, or composition pavement (both WMA and PCC)?

Conventional flexible pavement

(b). What is the project for (pavement rehabilitation or new road construction)?

Pavement rehabilitation

(c). Is the WMA only the surface course? What is the thickness of the WMA layer?

Yes, 3.5 Inches

(d). How about the traffic conditions (load spectra and volume)?

One project had >30.0 million ESALS other project 10.0>30.0 million ESALS

(e). Did the traffic design satisfy the actual traffic demand? Any overloading or any other concerns?

Unknown/no opinion

(f). How about the environmental conditions (precipitation data, ambient temperature data, subsurface moisture conditions, and subsurface temperature conditions)?

Placement took place during the summer and early fall, temperatures were normal (<70F) with no

significant precipitation.

(g) Could you explain more about the WMA project location, urban area or not, and how about the population around the pavement?

I-40, MP 355.0 to 359.5 – Rural Area – low population

I-25, MP 229.25 to 232.0 – Urban Area – high population

(h). What are the differences between WMA and HMA mix design, do you think?

Depends upon the WMA technology used. Some additives require no changes to current NMDOT mix design practices/requirements. Other technologies such as Foaming it is beneficial to have a laboratory foamer to utilize during the mix design process so that the designer has a better understanding of how the mix may react during production.

(i) Are there some advantages or disadvantages of combining RAP and WMA, comparing with RAP and HMA (such as the amount of RAP used, any effects)?

This is dependent upon the technology utilized. Some technologies cannot handle high RAP contents as adequate mixing of the materials becomes an issue at the lower temperatures. Other technologies allow greater RAP contents with no issues with adequate mixing. Utilizing RAP in WMA mixes has advantages as the lower mixing temperatures do not age the virgin binder as much as traditional HMA, this could lead to a softer binder blend (RAP binder/virgin binder) making the pavement less susceptible to low temperature cracking and allow higher percentages of RAP to be utilized.

(j). What are the differences between WMA and HMA pavement construction (such as pavement compactability, environmental benefits, length of construction season, haul distance, times of road construction and opening)?

Our experience has been that WMA pavements are easier to obtain in-place density over traditional HMA. We also were able to reduce our burner fuel consumption by roughly 30% utilizing WMA. The WMA also tends to remain workable longer than HMA allowing for a greater compaction window and easier handling of the mixture. The times in which the projects were constructed did not allow for the evaluation of extending the paving season but the industry opinion is that the paving season can be extended utilizing WMA. Our projects were located near the mixing plants so we were unable to evaluate the impact to haul distances but the fact that the mix remains workable longer would lead you to believe that the haul distance can be extended utilizing WMA. We were able to release traffic to the roadway on a daily basis within the same time frames as when utilizing HMA. Projects may be completed sooner reducing the impact to traffic if the paving season can be extended utilizing WMA as normally paving would be stopped in mid November causing the project to be completed the next spring, however, utilizing WMA could extend the paving season into and beyond December which may allow for the project to be completed months sooner than HMA. We are currently working on a project in another state in which we are utilizing WMA. This has allowed us to continue paving at temperatures of 30F whereas using HMA we would need to have 40F, this is allowing us to continue to pave and most likely will finish the project this year, had we not utilized WMA, we would have been required to stop paving operations and leave the project partially done through the winter until late spring, this would have had a significant impact to traffic during this time frame.

(k). Have you ever seen any surface and subsurface drainage problems in WMA pavements? (For example, pavement does not dry soon after rainfall.)?

None observed

(l). What are the differences of QA/QC data between WMA and HMA projects, do you think? What is differently done about the QA/QC of WMA project?

Depends on the technology utilized. Some WMA technologies only remain active for specific time frames i.e. Foaming, therefore testing time frames must be established and testing details must be worked out prior to beginning paving operations in order to account for this. Other technologies are not impacted by time or heating-reheating so testing can be performed in the same manner as HMA.

(m). Any other concerns about the WMA projects?

None

Question 3. This question is about concerns with WMA.

(a). The biggest concern about WMA is the amount of water left on the aggregate due to lower processing temperature. Does asphalt binder trap water as it coats the aggregate?

We did not experience any issues with this during our projects.

1). What moisture damage test (in the lab) did you do during the mix design stage?

AASHTO T283

2) What long-term effects (in the field) do you anticipate?

None as long as best practices are followed during the mixing/placement operations and adequate quality control is in place.

(b). Rutting resistance may be a concern for certain WMA technologies. The lower mixing and compaction temperatures for WMA cause the binder in WMA to age less than the binder in HMA, which indicates that WMA binder may be less stiff than HMA binder. Dose WMA have rutting problems after paving?

We did not experience any issues with rutting on our projects.

1). What rutting resistance test (in the lab) did you do during the mix design stage?

None are currently required

2) What long-term effects (in the field) do you anticipate?

I am unaware of any issues with rutting on any HMA/WMA placed on NM projects within the past 10 years, considering this, I do not anticipate any issues with rutting utilizing WMA.

(c). High contents of RAP can be incorporated into WMA due to the reduced aging of virgin asphalt. However, more than 20% RAP in a mix needs further binder testing to determine the PG of the blended binder. Have you ever done further tests to redetermine the PG of blended binder when the content of RAP is high? What tests did you do and how did the PG grade change?

We have not yet needed to do any additional binder testing as we did not exceed 25% RAP in our WMA but if given the opportunity to utilize greater than 25% RAP we will perform AASHTO T319/ASTM D5404, then test the recovered RAP binder and virgin binder according to AASHTO R29 and run the blending charts according to X1 of AASHTO M323 and X2.6 of AASHTO R35.

(d). Variability of RAP and the degree of blending between virgin binder also affect the performance of mix, especially at lowered mixing temperature. RAP needs lower temperature to be mixed. For your experience, was the low temperature good for the blended WMA binder? How was the homogeneity of the blended binder with RAP and virgin WMA?

We experienced no issues with the homogeneity of the WMA mix utilizing 25% RAP.

(e). For the plant concern with WMA, low baghouse temperature of WMA can cause condensation. Have ever seen some problems with the baghouse?

We anticipated this so we would start out at a higher temperature to get our baghouse up to temperature and then drop the temperature to WMA temperatures then at the end of the day we would increase the temperature to dry our baghouse before shutting down for the day. Another plant we have we were able to regulate the baghouse temperature using the valve without having to start and end at higher temperatures.

(f). The WMA technologies used in New Mexico are mainly Evotherm and Foaming. How do you feel about these two technologies? Which technology do you think better (such as cost and performance)?

We have used both and had success with both. Each one has benefits, Foaming is the most cost effective method while Evotherm has a higher cost but also allows for lower temperatures than Foaming. Both products have performed as expected so far so a difference in performance is yet to be determined.

(g) Any other concerns with WMA technologies (such as incomplete coating of aggregate, additional expense, and one more material/process to control)?

We have not experienced any quality issues with WMA, there is additional process control related to WMA but it is not significant. The only issue with WMA thus far is that it has not been consistently put into projects; this has slowed the ability of industry to maximize their operations for WMA and recoup the additional costs associated with WMA which is causing WMA to be slightly more expensive to produce and place.

Question 4. This question is about WMA pavements' performance in New Mexico.

(a). How are the pavements with WMA performing of your projects, any distress (cracking, deformation, deterioration and mat problems)?

No issues have been observed so far.

(b). Why do the pavements (in your answer (a) above) perform (good or bad) as they do, what do you think caused the pavement distress (mix design, construction, materials, climate, traffic, structural design and geometric design)?

Pavement has not been in place long enough to indicate any type of failures or issues.

(c). What do you think about WMA vs. HMA (serviceability and durability)?

Since the WMA placed to date in NM has not been in place long enough to yield any definite performance data only opinions can be offered at this time. Those opinions should be based upon the experiences during placement and the knowledge of the outcomes of other agencies that have been producing WMA for longer periods of time. Based upon the uniformity and increased in-place density utilizing WMA one can expect that WMA pavement should perform better. Also, as the binders are not aged as much during production of WMA one can conclude that that is beneficial to the longevity of the pavement and aid in the prevention of premature cracking, however one needs to keep in mind the condition of the underlying pavement structure that the WMA was placed on, the WMA will not be a cure for issues with the underlying pavement structure.

Question 5. What improvements can be made to the NMDOT's specification for WMA?

Prescriptive temperatures (upper and lower) should not be used. The Producer should have the ability to adjust the temperatures based upon the WMA technology utilized, placement/production conditions and the binder grade used. Allow the option of WMA for every project so that producers can optimize their operations for WMA.

APPENDIX C

GUIDELINES FOR PROJECT SELECTION AND MATERIALS SAMPLING, CONDITIONING, AND TESTING IN WMA RESEARCH STUDIES

The Guidelines for WMA testing are presented in this appendix.

TABLE C1 Field Project Selection for Short- And Long-Term Performance Studies.

Project and construction documentation	<p>NCAT and the University of Minnesota (for cold-climate projects) have developed detailed checklists for documenting field projects.</p> <p>Notes: Key considerations are (1) a condition survey of the existing pavement, (2) the pavement cross-section, (3) evaluation of pavement structural support, and (4) WMA production and compaction temperatures.</p>
Project Length	<p>The minimum test sections shall be 1/2 lane-mile in one travel lane located between intersections or interchanges. The plant temperature may be increased to produce control section. Shorter sections may be allowed if they are well planned and documented.</p> <p>Notes: The ideal production per test section is 800–1000 tons or 1/2- to 1 day production or 1 tanker load of binder (400–600 tons of non-foamed WMA); these amounts will vary depending on the nominal maximum aggregate size (NMAS) of the mix. Although 1 day’s production is often possible, test projects with control sections often are difficult to find. Selection of the minimum section length also must consider the type of WMA additive and where it is introduced.</p>
Minimum number of WMA technologies	<p>Minimum two technologies, plus a control. However, this minimum number may be waived, depending on whether the project is a new pavement or an overlay on an existing pavement.</p>
Control section definition	<p>The HMA control section must be identical to the WMA sections (including any RAP or RAS content) in all aspects but the presence of WMA, with the exception that the binder content of the control section may differ if necessary to attain identical air void contents in all sections.</p>

TABLE C1 (continued).

Other key features	<ul style="list-style-type: none">• WMA and control sections must be surface mixes in the same travel lane and with the same pavement support throughout all sections.• The correct mix discharge temperatures for the WMA must be verified throughout the project.• New projects are favored, but existing projects may be used if the necessary requirements are met. It is sometimes feasible to work with the state DOT and contractor to add WMA sections to an HMA project through a change order.• Specific and systematic performance monitoring plans are required for new versus existing WMA projects. Both plan types should include the provision for forensic analysis when pavements exhibit significant distress.• In the event that a WMA project of interest was constructed without a control section, it may be possible to pair the WMA project with an otherwise unconnected HMA project constructed with similar materials, structure, condition, traffic, and climate.• Future field projects should consider (a) roadway functional classification (average daily traffic [ADT] and trucks per day [% trucks]); (b) a variety of mix types (e.g., stone mastic asphalt and open-graded friction courses); and performance in intersections.• RAP and RAS are permitted as long as identical control mixes are available.• For overlay projects, the WMA and control sections must have comparable levels of existing distress.
--------------------	--

TABLE C2 Specimen Preparation Methods.

<p>WMA binder extraction and recovery</p>	<p>A procedure such as that of Minnesota DOT is required. In the Minnesota DOT procedure, asphalt binder extractions are performed using AASHTO T 164 Method A (Centrifuge Method). Toluene is used as the extraction solvent for the first two washes with an 85:15 v/v mixture of toluene and 95% ethanol used for the third wash. ASTM D5404—Standard Practice for Recovery of Asphalt from Solution Using Rotary Evaporator—is followed for the binder recovery method with the following modifications: Bath temperature and vacuum settings for toluene distillation (60°C, 100mBar). Fines are removed from the extract by high-speed centrifuging at 2000 RPM for 35 minutes after volume of asphalt extract is reduced to ~500ml.</p> <p>Notes:</p> <ul style="list-style-type: none"> • The FHWA memorandum Extraction and Recovery Procedures at TFHRC Asphalt Laboratories provides detailed information on a preferred method of binder extraction and recovery. • The use of trichloroethylene (TCE) as the extraction solvent is discouraged. TCE is known to harden recovered binders beyond the in-situ level. • Western Research Institute has developed an infrared spectroscopy method for detecting residual solvent in the recovered binder. • Research indicates that a higher temperature and vacuum than specified in ASTM D5404 may be required to effectively remove the toluene solvent from the recovered binder.
<p>WMA binders for mix design</p>	<p>Laboratory blending with low shear mechanical stirrer or foaming with laboratory foamed asphalt plant, per the proposed appendix to AASHTO R 35 (2).</p> <p>Notes:</p> <ul style="list-style-type: none"> • Aggregate coating is the key measure of foaming. Use coating to help guide selection of temperature. • Mix design may not require production of foamed binder in laboratory. Rather, it may be feasible to add water and binder to a bucket mixer containing aggregate and obtain comparable results. • At present, there are three commercial units for producing foamed asphalt. It is not known how these units compare. Further, it is very difficult to test the properties of foamed binder in bucket during production, and the foaming is typically lost during transfer of the binder for mixing with the aggregate. In practice, however, no problems have been identified with foamed WMA. • Future research is needed to better define the requirements for laboratory production of foamed asphalt.

TABLE C2 (continued).

<p>PMFC specimens for quality assurance and long-term performance testing</p>	<p>150-mm diameter cores: generally suitable for (a) bond strength, (b) in-place density and thickness, (c) air voids analysis, (d) IDT creep compliance and strength, (e) IDT dynamic modulus, (f) Hamburg Test, (g) Overlay Test, and (h) moisture sensitivity.</p> <p>Notes:</p> <ul style="list-style-type: none"> • Some low-temperature IDT testing may be done with 4-in. diameter specimens due to load requirements for 150-mm diameter specimens. • A core barrel with a 150-mm inside diameter should be used. • Due to lift thickness limitations, 150-mm pavement cores are generally not suitable for (a) dynamic modulus and (b) flow number.
<p>PMLC specimens for quality assurance</p>	<ul style="list-style-type: none"> • Verify mix design: 150-mm diameter ×115-mm high at Ndesign. • Moisture sensitivity and resilient modulus: 150-mm diameter ×95-mm high at 7.0±0.5% air voids. • Dynamic modulus, flow number, and AMPT fatigue: 100-mm diameter ×150-mm high cored and sawn from 150-mm diameter ×175-mm high specimens; 7.0±0.5% or field air voids. • Indirect Tensile Test (IDT) creep and strength: 150-mm diameter ×50-mm high. • Hamburg Test: 150-mm diameter ×62-mm high.
<p>LMLC specimens for mix design</p>	<ul style="list-style-type: none"> • Mix design: 150-mm diameter ×115-mm high at Ndesign. • Moisture sensitivity: 150-mm diameter ×95-mm high at 7.0±0.5% air voids. Note: Some researchers may also use complementary lower and higher air voids, e.g., 4.0% and 9.0%. • Dynamic modulus and flow number with AMPT: 100-mm diameter ×150-mm high cored and sawn from 150-mm diameter ×175-mm high specimens at 7.0±0.5% air voids, (per appendix to AASHTO R 35 and 2011 change to AASHTO TP 79). • IDT creep and strength: 150-mm diameter ×50-mm high prepared from gyratory specimen. Note: It is recommended to cut only one specimen from the center of each 115-mm high gyratory specimen. • Hamburg Test: 150-mm diameter ×62-mm high prepared from gyratory specimen. • Beam Fatigue Test: 380-mm long ×63-mm wide ×50-mm high beams cut from rolling wheel compacted slabs. • Overlay Test: 150-mm diameter ×115-mm high.

TABLE C3 Required Conditioning Methods.

PMFC Specimens	
Drying as needed.	Take precautions when drying PMFC specimens at elevated temperatures to avoid damaging them.
PMLC Specimens	
16 hours at 140 °F (per AASHTO T 283), then 2 to 2.5 hours at compaction temperature.	For WMA and HMA dynamic modulus (AASHTO TP 79), flow number (AASHTO TP 79), and moisture sensitivity (AASHTO T 283 and T324). Notes: <ul style="list-style-type: none"> • This conditioning is intended to simulate aging after approximately 1-2 years in service. • The flow number measured before this conditioning may be indicative of the propensity of the mixture to early rutting.
From ambient temperature, reheat to compaction temperature for a target period of 2.5 hours.	For volumetric analysis.
For samples not at ambient temperature, note the temperature and reheat to compaction temperature, noting the time.	For volumetric analysis.
Long-term aging (AASHTO R 30), 5 days at 85°C (after conditioning for rutting tests).	For WMA and HMA fatigue testing (AASHTO T 321 and TX-248-F), and low-temperature cracking testing (AASHTO T 322). Note: This conditioning is generally done on bulk specimens, but may be done on cored and sawn specimens if desired.
Recommended minimum time between fabrication and testing.	5 days.
Recommended maximum time between fabrication and testing.	20 to 30 days unless specimens are properly vacuum sealed and stored. Record times and temperatures of storage.

TABLE C3 (continued).

LMLC Specimens	
<p>2 hours at WMA construction compaction temperature.</p>	<p>For WMA mix design and volumetric analysis, moisture sensitivity (AASHTO T 283 and T 324) and flow number (AASHTO TP 79).</p> <p>Notes:</p> <ul style="list-style-type: none"> • This is the short-term conditioning recommended by NCHRP Project 9-43 as the best representation of aging at construction. • This recommendation leads to decreased flow number requirements for WMA compared to HMA and possibly lower binder contents compared to an equivalent HMA mixture, and was based on data from mixtures with aggregate absorptions of 1.0% or less. • The flow number measured under these conditions may be indicative of a propensity of the mixture to early rutting. • For WMA mixtures containing RAP or RAS, the compaction temperature is that for the virgin binder.
<p>2 hrs at WMA construction compaction temperature, then 16 hours at 140°F (per AASHTO T 283), then 2 to 2.5 hours at compaction temperature.</p>	<p>For WMA and HMA dynamic modulus (AASHTO TP 79), flow number (AASHTO TP 79), and moisture sensitivity (AASHTO T 283 and T 324).</p> <p>Notes:</p> <ul style="list-style-type: none"> • This conditioning is intended to simulate aging after approximately 1 to 2 years in service. • Measurement of Gmm after conditioning provides an indication of extended binder absorption.
<p>Long-term aging (per AASHTO R 30), 5 days at 85°C (after conditioning for rutting tests)</p>	<p>For WMA and HMA fatigue testing (AASHTO T 321 and TX-248-F) and low temperature cracking testing (AASHTO T 332).</p> <p>Note:</p> <p>This conditioning is generally done on bulk specimens, but may be done on cored and sawn specimens if desired.</p>

TABLE C4 LMLC Specimens: Required Performance Testing for Mix Design.

Modulus	
Dynamic modulus	AASHTO TP 79. Note: Provides necessary input data for pavement analysis with DARWin-ME.
Rutting	
Flow number	AASHTO TP 79. Note: Follow the procedure in Section 8.5 of the draft appendix to AASHTO R 35.
Hamburg Test	AASHTO T 324 performed for moisture sensitivity. Note: Prepare specimens at air voids content of 7±1% and conduct test at standard conditions: 50°C under water.
Thermal (Low-temperature) Cracking	
IDT creep compliance and strength	AASHTO T 322. Note: Provides necessary input data for pavement analysis with DARWin-ME.
Durability	
Moisture sensitivity	AASHTO T 283. Note: 1 freeze/thaw cycle
Hamburg Test	AASHTO T 324. Note: Prepare specimens at air voids content of 7±1% and conduct test at standard conditions: 50°C under water.
Fatigue Cracking	
Beam Fatigue Test	ASTM D7460 in strain control.
Overlay Test	Strong alternative: Tex-248-F, Test Procedure for Overlay Test, January 2009.
Other	
Volumetric mix design	Per the procedure in the draft appendix to AASHTO R 35.
Compactability	Per the procedure in section 8.3 of the draft appendix to AASHTO R 35.
Coating	AASHTO T 195, in accordance with the guidance in section 8.2 of the draft appendix to AASHTO R 35. Note: Be aware of the inherent variability of the method and potential variability in results between different types of mixers

TABLE C5 PMLC Specimens: Required Performance Testing for Quality Assurance.

Modulus	
Dynamic modulus	AASHTO TP 79. Note: Provides necessary input data for pavement analysis with DARWin-ME.
Rutting	
Flow number	AASHTO TP 79.
Hamburg Test	AASHTO T 324 performed for moisture sensitivity. Note: Prepare specimens at air voids content of 7±1% and conduct test at standard conditions: 50°C under water.
Thermal (Low-temperature) Cracking	
IDT creep compliance and strength	AASHTO T 322. Note: Provides necessary input data for pavement analysis with DARWin-ME.
Semi-Circular Bending Test	Strong alternative: Per Li and Marasteanu ¹ .
Durability	
Moisture sensitivity	AASHTO T 283. Note: 1 freeze/thaw cycle
Hamburg Test	AASHTO T 324. Note: Prepare specimens at air voids content of 7±1% and conduct test at standard conditions: 50°C under water.
Fatigue Cracking	
Beam Fatigue Test	ASTM D7460 in strain control.
Overlay Test	Strong alternative: Tex-248-F, Test Procedure for Overlay Test, January 2009.
Other	
G _{mm} (AASHTO T 209)	AASHTO T 209.
Volumetric properties	AASHTO R 35.
Gyratory compaction to N _{design}	AASHTO T 312.

Note: ¹ Li, X.-J. and M.O. Marasteanu, Using Semi-Circular Bending Test to Evaluate Low-Temperature Fracture Resistance for Asphalt Concrete, *Experimental Mechanics*, Vol. 50 No. 7, 2010, pp. 867-876.

TABLE C6 PMFC Specimens: Required Performance Testing for Quality Assurance and Long-Term Performance.

Modulus	
Dynamic modulus by IDT method	Per the procedure in Kim, Seo, et al ¹ .
Spectral analysis of seismic waves (SASW)	Strong alternative.
Rutting	
Hamburg Test	AASHTO T 324 performed for moisture sensitivity. Note: Prepare specimens at air voids content of 7±1% and conduct test at standard conditions: 50°C under water.
Thermal (Low-temperature) Cracking	
IDT creep compliance and strength	AASHTO T 322. Note: Provides necessary input data for pavement analysis with DARWin-ME.
Semi-Circular Bending Test	Strong alternative: Per Li and Marasteanu ² .
Durability	
Moisture sensitivity	AASHTO T 283. Note: 1 freeze/thaw cycle
Hamburg Test	AASHTO T 324 performed for moisture sensitivity. Note: Prepare specimens at air voids content of 7±1% and conduct test at standard conditions: 50°C under water.
Bond strength between layers	For forensic analysis, as necessary. Per the procedure in West, Zhang, and Moore ³ .
Fatigue Cracking	
Overlay Test	Strong alternative: Tex-248-F, Test Procedure for Overlay Test, January 2009.
Pavement Condition	
Visual distress survey	Per the FHWA LTPP Protocol.
Rut depth profile	
In-place thickness and density	Core or SASW measurements.
Smoothness (IRI)	With cooperation of state DOT.
FWD	As needed for forensic analysis. Per the FHWA LTPP Protocol.
Permeability	As needed for forensic analysis. Per the method in Cooley ⁴ .
G _{mb}	AASHTO T 166 or T 331.
G _{mm}	AASHTO T 209.
Air voids analysis	AASHTO T 269.
Absorption (by calculation)	
DSR torsion bar	

Note: ¹ Kim, Y.R., Y. Seo, et al., Dynamic Modulus Testing of Asphalt Concrete in Indirect Tension Mode, *Transportation Research Record: Journal of the Transportation Research Board*, No. 1891, Transportation Research Board of the National Academies, Washington, D.C., 2004, pp. 163–73.

² Li, X.-J. and M.O. Marasteanu, Using Semi-Circular Bending Test to Evaluate Low-Temperature Fracture Resistance for Asphalt Concrete, *Experimental Mechanics*, Vol. 50 No. 7, 2010, pp. 867-876.

³ West, R.C., J. Zhang, and J. Moore. NCAT Report 05-08: Evaluation of Bond Strength Between Pavement Layers. National Center for Asphalt Technology, Auburn University, Auburn AL, 2005.

⁴ Cooley, L.A. NCAT Report 99-01: Permeability of Superpave Mixtures: Evaluation of Field Permeameters. National Center for Asphalt Technology, Auburn University, Auburn AL, 1999.

TABLE C7 Summary of Performance Testing and Specimen Conditioning.

Performance Testing					
Sample Type	Modulus	Rutting	Low-Temperature Cracking	Durability	Fatigue Cracking
LMLC PMLC	<ul style="list-style-type: none"> • Dynamic modulus (AMPT) 	<ul style="list-style-type: none"> • Flow number (AMPT) • Hamburg Test 	<ul style="list-style-type: none"> • IDT • Semi-Circular bending Test 	<ul style="list-style-type: none"> • Lottman Test • Hamburg Test 	<ul style="list-style-type: none"> • Beam Fatigue Test • Overlay Test
PMFC	<ul style="list-style-type: none"> • IDT • SASW 	<ul style="list-style-type: none"> • Hamburg Test 	<ul style="list-style-type: none"> • IDT • Semi-Circular bending Test 	<ul style="list-style-type: none"> • Lottman Test • Hamburg Test 	<ul style="list-style-type: none"> • Overlay Test

Specimen Conditioning				
Sample Type	Test For	Conditioning		
		2 hrs @ WMA compaction temperature	2 hrs @ WMA compaction temperature 16 hrs @ 140 °F +2 hrs @ WMA compaction temperature	2 hrs @ WMA compaction temperature 16 hrs @ 140 °F +2 hrs @ WMA compaction temperature +5 days @ 85°C
LMLC	Mix design/volumetric analysis	X		
	Modulus		X	
	Rutting	X	X	
	Low-temperature cracking			X
	Durability	X	X	
	Fatigue cracking			X

TABLE C7 (continued).

Sample Type	Test For	Conditioning		
		2 hrs @ WMA compaction temperature	16 hrs @ 140 °F +2 hrs @ WMA compaction temperature	2 hrs @ WMA compaction temperature 16 hrs @ 140 °F +2 hrs @ WMA compaction temperature +5 days @ 85°C
PMLC	Volumetric analysis	X		
	Modulus		X	
	Rutting		X	
	Low-temperature cracking			X
	Durability		X	
	Fatigue cracking			X

Sample Type	Test For	Conditioning		
		2 hrs @ WMA compaction temperature	16 hrs @ 140 °F +2 hrs @ WMA compaction temperature	2 hrs @ WMA compaction temperature 16 hrs @ 140 °F +2 hrs @ WMA compaction temperature +5 days @ 85°C
PMFC	Volumetric analysis	Dry and test		
	Modulus			
	Rutting			
	Low-temperature cracking			
	Durability			
	Fatigue cracking			

Note: For specimens of mixture at ambient temperature, reheat them at WMA compaction temperature for 2.5 hours. For specimens of mixture not at ambient temperature, reheat them at WMA compaction temperature and note time.

TABLE C8 Aggregate and Binder Testing.

Aggregates	
Flat and elongated or AIMS method	ASTM D 4791 or use state or contractor data.
Gradation	AASHTO T 27.
LA Abrasion Test or Micro Deval Test	AASHTO T 96 or T 327 or use state or contractor data.
Bulk specific gravity and absorption	AASHTO T 84 and T 85.
Geologic type	Yes or use state or contractor data.
Fine aggregate, uncompacted voids	AASHTO T 304 or use state or contractor data.
Coarse aggregate angularity	AASHTO T 335 or use state or contractor data.
Sand equivalent	AASHTO T 176 or use state or contractor data.
Stockpile moisture content	AASHTO T 255 or use state or contractor data.
Soundness	AASHTO T 104 or use state or contractor data.
Binders	
Frequency sweep to develop master curve	
Continuous performance grade of extracted WMA binder	AASHTO R 29 without RTFO aging. Note: Done before and after PAV aging. Use a DSR capable of handling stiff binders.
Multiple Stress Creep Recovery Test	AASHTO TP 70
Continuous performance grade of original WMA binder, to include modifiers added at the plant	AASHTO R 29. Note: Use a DSR capable of handling stiff binders.
Linear Amplitude Sweep Test	Per Hintz, Velasquez, et al ¹ .
Aging Index	

Note: ¹ Hintz, C.S., R. Velasquez, C. Johnson, and H. Bahia. Modification and Validation of the Linear Amplitude Sweep Test for Binder Fatigue Specification. Presented at the 90th Annual Meeting of the Transportation Research Board, Washington, D.C., 2011.



New Mexico Department of Transportation
RESEARCH BUREAU
7500B Pan American Freeway NE
PO Box 94690
Albuquerque, NM 87199-4690
Tel: (505) 841-9145